

This copy is a reprint which includes current pages from Changes 1 through 5.

**TECHNICAL MANUAL**

**OPERATOR'S, ORGANIZATIONAL, AND  
DIRECT SUPPORT MAINTENANCE MANUAL,  
INCLUDING REPAIR PARTS  
AND SPECIAL TOOLS LIST  
FOR**

**PUMP, RECIPROCATING, POWER-DRIVEN,**

**DIAPHRAGM, GASOLINE-ENGINE-DRIVEN,  
WHEEL-MOUNTED  
PEABODY BARNES MODEL  
US40CDG  
4320-01-092-2210**

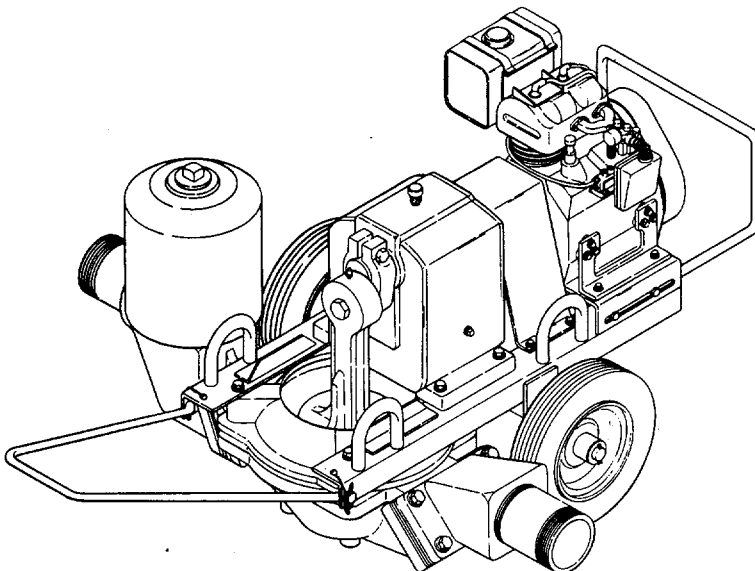

<b>INTRODUCTION</b>	<b>1-1</b>
<b>OPERATING INSTRUCTIONS</b>	<b>2-1</b>
<b>OPERATOR/CREW MAINTENANCE INSTRUCTIONS</b>	<b>3-1</b>
<b>ORGANIZATIONAL MAINTENANCE INSTRUCTIONS</b>	<b>4-1</b>
<b>DIRECT SUPPORT MAINTENANCE INSTRUCTIONS</b>	<b>5-1</b>
<b>REFERENCES</b>	<b>A-1</b>
<b>MAINTENANCE ALLOCATION CHART</b>	<b>B-1</b>
<b>REPAIR PARTS AND SPECIAL TOOLS LIST</b>	<b>C-1</b>
<b>EXPENDABLE SUPPLIES AND MATERIALS LIST</b>	<b>D-1</b>
<b>GLOSSARY</b>	
<b>ALPHABETICAL INDEX</b>	

**HEADQUARTERS, DEPARTMENT OF THE ARMY**

**1 MARCH 1983**

CHANGE  
NO. 5

HEADQUARTERS  
DEPARTMENT OF THE ARMY  
WASHINGTON, D. C. 15 October 1993

Operator's, Organizational, and Direct Support Maintenance Manual  
Including Repair Parts and Special Tools List  
For

PUMP, RECIPROCATING, POWER-DRIVEN,  
DIAPHRAGM, GASOLINE-ENGINE-DRIVEN,  
WHEEL-MOUNTED  
PEABODY BARNES MODEL  
US4OCDG  
4320-01-092-2210

DISTRIBUTION STATEMENT A: Approved for public release; distribution is unlimited.

TM 5-4320-275-13&P, 1 March 1983, is changed as follows:

1. Remove and insert pages as indicated below. New or changed text material is indicated by a vertical bar in the margin. An illustration change is indicated by a miniature pointing hand.

Remove pages

i and ii  
1-1 and 1-2  
C-17 and C-18  
C-25 and C-26

Insert pages

i and ii  
1-1 and 1-2  
C-17 and C-18  
C-25 and C-26

2. Retain this sheet in front of manual for reference purposes.

By Order of the Secretary of the Army:

Official:

GORDON R. SULLIVAN  
*General, United States Army*  
*Chief of Staff*

MILTON H. HAMILTON  
*Administrative Assistant to the*  
*Secretary of the Army*  
05529

DISTRIBUTION:

To be distributed in accordance with DA Form 12-25-E, block no. 1426, requirements for TM 5-4320-275-13&P.

CHANGE  
NO. 4

HEADQUARTERS  
DEPARTMENT OF THE ARMY  
WASHINGTON, D. C. , 25 January 1991

Operator's, Organizational, and Direct Support Maintenance Manual  
Including Repair Parts and Special Tools List  
For

PUMP, RECIPROCATING, POWER-DRIVEN,  
DIAPHRAGM, GASOLINE-ENGINE-DRIVEN,  
WHEEL-MOUNTED  
PEABODY BARNES MODEL  
US40CDG  
4320-01-092-2210

Approved for public release; distribution is unlimited

TM 5-4320-275-13&P, 1 March 1983, is changed as follows:

1. Remove and insert pages as indicated below. New or changed text material is indicated by a vertical bar in the margin. An illustration change is indicated by a miniature pointing hand.

Remove pages

Insert pages

C-11 through C-14  
C-25 and C-26

C-11 through C-14  
C-25 and C-26

2. Retain this sheet in front of manual for reference purposes.

**By Order of the Secretary of the Army:**

**CARL E. VUONO**  
*General, United States Army*  
*Chief of Staff*

**Official:**

**THOMAS F. SIKORA**  
*Brigadier General, United States Army*  
*The Adjutant General*

**DISTRIBUTION:**

To be distributed in accordance with DA Form 12-25E, (qty rqr block no. 1426)

CHANGE

No. 3

HEADQUARTERS  
DEPARTMENT OF THE ARMY  
WASHINGTON, D. C. , 4 April 1988

Operator's, Organizational, and  
Direct Support Maintenance Manual  
Including Repair Parts and Special Tools List  
For  
PUMP, RECIPROCATING, POWER-DRIVEN,  
DIAPHRAGM, GASOLINE-ENGINE-DRIVEN,  
WHEEL-MOUNTED  
PEABODY BARNES MODEL  
US40CDG  
4320-01-092-2210

TM 5-4320-275-13 & P, 1 March 1983, is changed as follows:

1. Remove and insert pages as indicated below. New or changed text material is indicated by a vertical bar in the margin. An illustration change is indicated by a miniature pointing hand.

Remove pages

i and ii  
1-1 and 1-2  
4-83 and 4-84  
A-1/A-2  
B-1 through B-6

Insert pages

i and ii  
1-1 and 1-2  
4-83 and 4-84  
A-1/A-2  
B-1 through B-6

2. Retain this sheet in front of manual for reference purposes.

**By Order of the Secretary of the Army:**

**CARL E. VUONO**  
*General, United States Army*  
*Chief of Staff*

**Official:**

**R. L. DILWORTH**  
*Brigadier General, United States Army*  
*The Adjutant General*

**DISTRIBUTION:**

To be distributed in accordance with DA Form 12-25A, Operator's, Unit, and Direct Support and General Support Maintenance requirements for Pump, Reciprocating, Diaphragm, Gas Driven, Power Driven, Wheel Mounted (US40CDG) (TM 5-4320-275-13&P)

CHANGE  
NO 2

HEADQUARTERS  
DEPARTMENT OF THE ARMY  
WASHINGTON, D. C. , 30 November 1987

Operator's Organizational, and  
Direct Support Maintenance Manual,  
Including Repair Parts and Special Tools List  
For  
PUMP, RECIPROCATING, POWER-DRIVEN,  
DIAPHRAGM, GASOLINE-ENGINE-DRIVEN,  
WHEEL-MOUNTED  
PEABODY BARNES MODEL  
US40CDG  
4320-01-092-2210

TM 5-4320-275-13&P, 1 March 1983, is changed as follows:

1. Remove and insert pages as indicated below. New or changed text material is indicated by vertical bar in the margin. An illustration change is indicated by a miniature pointing hand.

Remove pages

Insert pages

C-17 and C-18  
C-25 and C-26

C-17 and C-18  
C-25 and C-26

2. Retain this sheet in front of manual for reference purposes.

**By Order of the Secretary of the Army:**

**CARL E. VUONO**  
*General, United States Army*  
*Chief of Staff*

Official:

**R. L. DILWORTH**  
*Brigadier General, United States Army*  
*The Adjutant General*

**DISTRIBUTION:**

To be distributed in accordance with DA Form 12-25A, Operator, Unit, and Direct Support and General Support Maintenance Requirements for Pump, Reciprocating, Diaphragm, Gas Driven, Power Driven, Wheel Mounted (US40CDG).

CHANGE

No. 1

HEADQUARTERS  
DEPARTMENT OF THE ARMY  
WASHINGTON, D. C. , 2 September 1986

Operator's, Organizational, and  
Direct Support Maintenance Manual,  
Including Repair Parts and Special Tools List  
For

PUMP, RECIPROCATING, POWER-DRIVEN,  
DIAPHRAGM, GASOLINE-ENGINE-DRIVEN,  
WHEEL-MOUNTED  
PEABODY BARNES MODEL  
US40CDG  
4320-01-092-2210

TM 5-4320-275-13 & P, 1 March 1983, is changed as follows:

1. Remove and insert pages as indicated below. New or changed text material is indicated by a vertical bar in the margin. An illustration change is indicated by a miniature pointing hand.

Remove pages

C-7 and C-8  
C-13 through C-16  
C-21 through C-26

Insert pages

C-7 and C-8  
C-13 through C-16  
C-21 through C-26

2. Retain this sheet in front of manual for reference purposes.

**By Order of the Secretary of the Army:**

**JOHN A. WICKHAM, JR.**  
*General, United States Army*  
*Chief of Staff*

**Official:**

**R. L. DILWORTH**  
*Brigadier General, United States Army*  
*The Adjutant General*

**DISTRIBUTION:**

to be distributed in accordance with DA Form 12-31, Operator's, Organizational, Direct Support and General Support Maintenance requirements for Pump, Reciprocating, Diaphragm, Gas Driven, Power Driven, Wheel Mounted (US40CDG) (TM 5-4320-275-13&P)

**WARNING****CARBON MONOXIDE**

is produced by the internal combustion engine of this pump.

**DEATH**

may result if personnel fail to observe safety precautions.

Carbon monoxide is a colorless, odorless, deadly poisonous gas which, when breathed, deprives the body of oxygen and causes suffocation. Exposure to air contaminated with carbon monoxide produces symptoms of headache, dizziness, loss of muscle control, or apparent drowsiness. Coma, permanent brain damage, or death can result from severe exposure.

Carbon monoxide occurs in the, exhaust fumes of internal combustion engines and becomes dangerously concentrated under conditions of inadequate ventilation. Observe the following safety precautions whenever the engine is running:

- Perform tests outdoors or in a well-ventilated area.
- Do not idle the engine for long periods without maintaining adequate ventilation.
- Be alert at all times for exhaust odors and exposure symptoms.
- Be aware: the field protective mask for chemical-biological-radiological (CBR) protection will not protect you from carbon monoxide poisoning.

Expose victims to fresh air, keep warm, and do not permit physical exercise. For artificial respiration, refer to FM21-11.

**SEVERE BURNS**

illness, death, or injury may result if personnel fail to handle gasoline properly. Observe the following safety precautions:

- Do not inhale vapor.
- Do not refuel a hot or running engine.
- Do not refuel near open flame, sparks, or excessive heat.
- Be certain fuel lines and connections are secure.
- Do not overfill the fuel tank.
- Work in a well-ventilated area.

Allow an engine and pump to cool before performing any service or maintenance.

**WARNING**

**PERSONAL INJURY**

may result if the engine cutoff switch is not turned off for service or maintenance.

**ELECTRICAL SHOCK**

may result from performing maintenance while the engine is running. The ignition system of this engine contains dangerous voltages which can cause severe electrical shock.

**HEALTH AND SAFETY HAZARD**

exists when cleaning solvents are used. Clean all parts in a well-ventilated area. Avoid inhalation of solvent fumes and prolonged exposure of skin to cleaning solvent. Wash exposed skin thoroughly. Dry cleaning solvent (fed. spec. P-D-680) used to clean parts is potentially dangerous to personnel and property. Do not use near open flame or excessive heat. Flash point of solvent is 100° to 138°F (38° to 59°C).

**EYE INJURY**

may result when parts are cleaned with compressed air. Use approved safety glasses, goggles, or face shield to prevent eye injury.

**EXPLOSION HAZARD**

exists when welding repairs are attempted on fuel tank.

**b**



**OPERATOR'S, ORGANIZATIONAL, AND  
DIRECT SUPPORT MAINTENANCE MANUAL,  
INCLUDING REPAIR PARTS AND SPECIAL TOOLS LIST**  
for  
**PUMP, RECIPROCATING, POWER-DRIVEN,  
DIAPHRAGM, GASOLINE-ENGINE-DRIVEN,  
WHEEL-MOUNTED PEABODY BARNES MODEL  
US40CDG  
4320401-092-2210**  
Current as of 1 October 1982

**REPORTING ERRORS AND RECOMMENDING IMPROVEMENTS**

You can help improve this manual. If you find any mistake or if you know of a way to improve the procedures, please let us know. Mail your letter, DA Form 2028 (Recommended Changes to Publications and Blank Forms). or DA Form 2028-2 located in the back of this manual directly to: Commander, U. S. Army Aviation and Troop Command, ATTN: AMSAT-I-MP, 4300 Goodfellow Blvd. , St. Louis, MO 63120. A reply will be furnished to you.

**DISTRIBUTION STATEMENT A: Approved for public release; distribution is unlimited**

		<b>Page</b>	<b>Illus Figure</b>
CHAPTER 1.	INTRODUCTION .....	1-1	
Section I.	General Information .....	1-1	
Section II.	Equipment Description and Data .....	1-2	
Section III.	Principles of Operation .....	1-5	
CHAPTER 2.	OPERATING INSTRUCTIONS .....	2-1	
Section I.	Description and Use of Operator's Controls and Indicators .....	2-1	
Section II.	Operator/Crew Preventive Maintenance Checks and Services .....	2-2	
Section III.	Operation Under Usual Conditions .....	2-5	
Section IV.	Operation Under Unusual Conditions .....	2-10	
CHAPTER 3.	OPERATOR/CREW MAINTENANCE INSTRUCTIONS .....	3-1	
Section I.	Lubrication Instructions .....	3-1	
Section II.	Troubleshooting Procedures .....	3-1	
Section III.	Maintenance Procedures .....	3-4	
CHAPTER 4.	ORGANIZATIONAL MAINTENANCE INSTRUCTIONS .....	4-1	
	Chapter Overview .....	4-1	
Section I.	Repair Parts, Special Tools, TMDE, and Support Equipment .....	4-1	
Section II.	Service Upon Receipt.....	4-2	4-1
Section III.	Operational Checks .....	4-5	
Section IV.	Preventive Maintenance Checks and Services .....	4-7	
Section V.	Troubleshooting .....	4-14	
Section VI.	Maintenance Procedures .....	4-23	
Section VII.	Preparation for Storage or Shipment .....	4-84	

		<b>Page</b>	<b>Illus Figure</b>
CHAPTER 5.	DIRECT SUPPORT MAINTENANCE INSTRUCTIONS .....	5-1	
	Chapter Overview .....	5-1	
Section I.	Repair Parts, Special Tools, TMDE, and Support Equipment ...	5-1	
Section II.	Troubleshooting .....	5-2	
Section III.	Maintenance Procedures .....	5-3	
APPENDIX A.	REFERENCES .....	A-1	
APPENDIX B.	MAINTENANCE ALLOCATION CHART .....	B-1	
Section I.	Introduction .....	B-1	
Section II.	Maintenance Allocation Chart .....	B-4	
Section III.	Tool and Test Equipment Requirements .....	B-5	
Section IV.	Remarks .....	B-5	
APPENDIX C.	ORGANIZATIONAL AND DIRECT SUPPORT MAINTENANCE REPAIR PARTS AND SPECIAL TOOLS LIST .....	C-1	
Section I.	Introduction .....	C-1	
Section II.	Repair Parts List .....	C-7	
	Group 01    Engine		
	Engine Assembly .....	C-7	1
	Group 02    Fuel System		
	Tank, Line, Fittings and Filter .....	C-9	2
	Group 03    Frame		
	Frame Assembly and Wheels .....	C-11	3
	Group 04    Accessory Items		
	Data Plates .....	C-13	4
	Suction Hose .....	C-15	5
	Group 05    Pump		
	Accumulator, Check Valve Assemblies and		
	Discharge Port .....	C-17	6
	Diaphragm .....	C-19	7
	Connecting Rod Assembly .....	C-21	8
	Gear Reducer .....	C-23	9
Section III.	Special Tools List (Not Applicable) .....		
Section IV.	National Stock Number and Part Number Index .....	C-25	
APPENDIX D.	EXPENDABLE SUPPLIES AND MATERIALS LIST .....	D-1	
GLOSSARY	.....	Glossary 1	
ALPHABETICAL INDEX	.....	Index 1	

## HOW TO USE THIS MANUAL

This manual consists of:

1. Introduction to Model US40CDG Diaphragm Pump.
2. Principles of operation describing the functions of the diaphragm pump.
3. Maintenance instructions for operator, organizational, and direct support maintenance. These chapters contain:
  - a. Information on repair parts, special tools, test, measurement and diagnostic equipment (TMDE), and support equipment
  - b. Instructions for service upon receipt of the diaphragm pump
  - c. Operational checks
  - d. Preventive maintenance checks and services (PMCS)
  - e. Troubleshooting
  - f. Maintenance procedures
4. Appendixes in the back of the manual list:
  - a. References
  - b. Maintenance Allocation Chart
  - c. Repair parts and special tools
  - d. Expendable supplies and materials

You will need to perform operational checks and PMCS on a regular basis. The information in these sections is in tabular form so you can use it more easily.

The troubleshooting data is coded by malfunction number. The symptom index on page 4-14 or 5-2 is your guide to these malfunctions. Read through the applicable symptom index if the diaphragm pump is not working right.

Instructions for

- Inspecting the diaphragm pump
- Testing the diaphragm pump
- Adjusting the diaphragm pump
- Replacing authorized assemblies

are presented in tabular form to make them easier to use. Each repair paragraph describes one specific task. As much as possible, complete instructions are included. There are some paragraphs which make you look in other places in the manual, but this has been avoided whenever possible. For procedures that apply to the engine refer to TM 5-2805-257-14. The engine Repair Parts and Special Tool List is TM 5-2805-257-24P.

## CHAPTER 1 INTRODUCTION

---

### Section I. GENERAL INFORMATION

#### 1-1. SCOPE

Type of Manual: Operator's, Organizational, and Direct Support Maintenance  
Model Number and Equipment Name: US40CDG Diaphragm Pump  
Purpose of Equipment: Pumps water containing solids

#### 1-2. MAINTENANCE FORMS, RECORDS, AND REPORTS

Department of the Army forms and procedures used for equipment maintenance will be those prescribed by DA PAM 738-750, The Army Maintenance Management System.

#### 1-3. DESTRUCTION OF ARMY MATERIAL TO PREVENT ENEMY USE

Refer to TM 750-244-3 for instructions.

#### 1-4. PREPARATION FOR STORAGE AND EQUIPMENT

Instructions for preparation for storage and shipment are in Chapter 4.

#### 1-5. REPORTING EQUIPMENT IMPROVEMENT RECOMMENDATIONS (EIR)

EIR's can and must be submitted by anyone who is aware of an unsatisfactory condition with the equipment design or use. It is not necessary to show a new design or list a better way to perform a procedure; simply tell why the design is unfavorable or why a procedure is difficult. EIR's may be submitted on SF 368 (Quality Deficiency Report). Mail directly to Commander, U. S. Army Aviation and Troop Command, ATTN: AMSAT-I-MDO, 4300 Goodfellow Blvd., St. Louis, MO 63120. A reply will be furnished to you.

## Section II. EQUIPMENT DESCRIPTION AND DATA

### 1-6. PURPOSE OF DIAPHRAGM PUMP

Pumps water containing solids

### 1-7. CHARACTERISTICS

- Constant speed operation
- Wheel mounted for mobility
- Self-priming

### 1-8. CAPABILITIES AND FEATURES

- Replaceable flapper valves
- Easy to remove obstructions from valve areas
- Speed-reduction system for fixed control of operating rate
- Engine cutoff switch for positive control
- Permanently affixed tiedown provisions

### 1-9. LOCATION AND DESCRIPTION OF EXTERNAL COMPONENTS

- (A) ENGINE. Power source.
- (B) COUPLING GUARD. Metal safety cover.
- (C) GEAR REDUCER. Speed reduction unit.
- (D) CRANK. Attaches to gear reducer and connecting rod.
- (E) CONNECTING ROD. Attaches to pump.
- (F) ACCUMULATOR. Reservoir.
- (G) INLET FITTING.
- (H) DRAW BAR.

- (I) OUTLET FITTING.
- (J) WHEEL.
- (K) FRAME.
- (L) ENGINE MOUNT. Mounts engine to frame.
- (M) FUEL TANK. Mounts to engine.
- (N) ENGINE GUARD. Metal bumper for engine protection.
- (O) SUCTION HOSE.

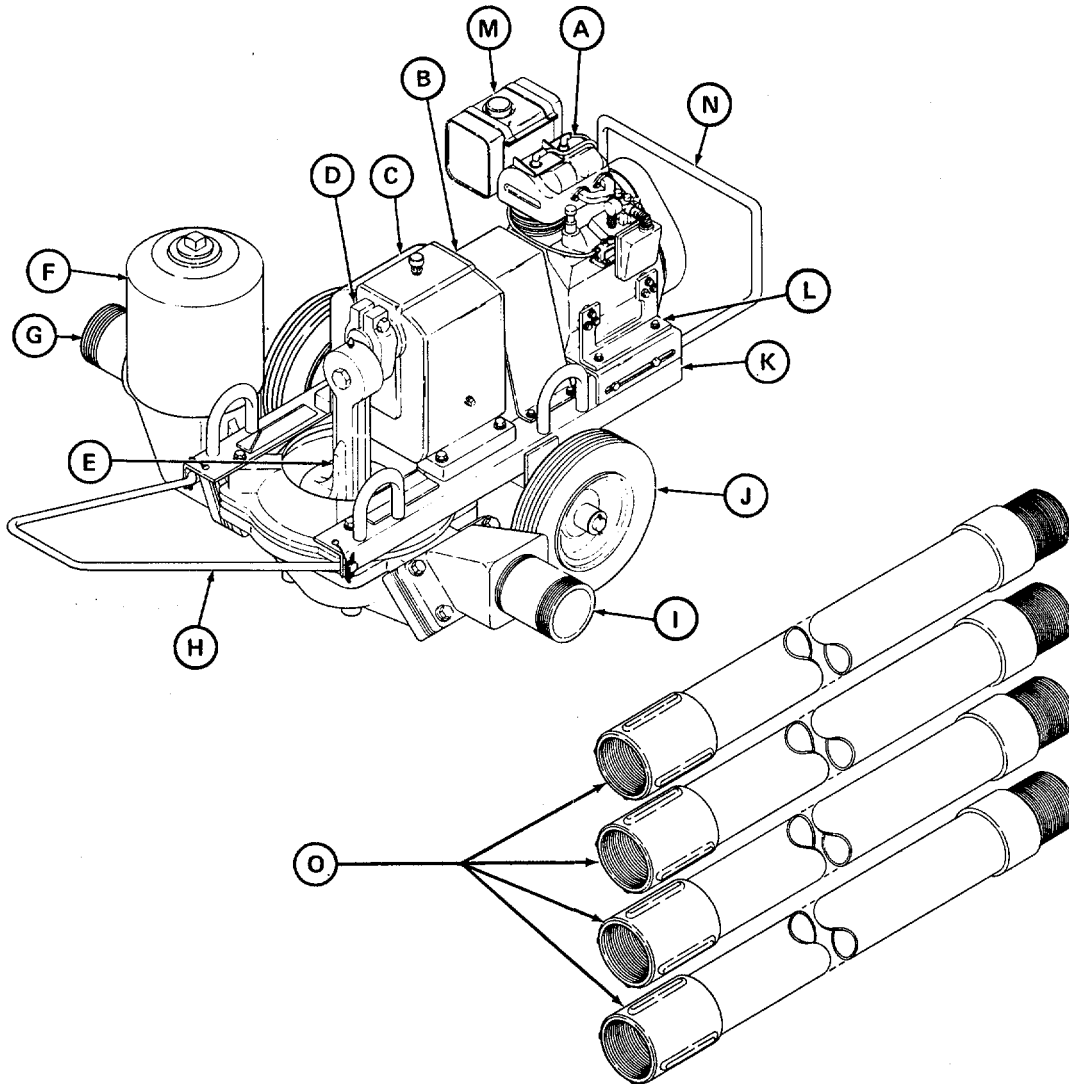

**1-10. IDENTIFICATION**

The diaphragm pump has two identification plates, as follows:

a. *Operating procedure plate.* The operating procedure plate is located on the coupling guard. It provides lubrication points with type of lubricant and illustrates tiedown slinging provisions.

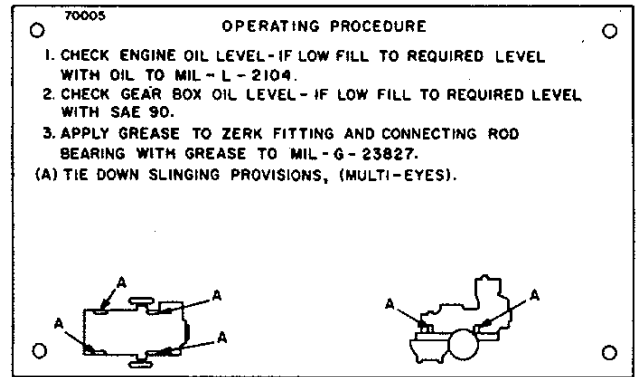

b. *Identification plate.* The identification plate is located on the coupling guard. It provides the pump nomenclature, national stock number, pump and engine serial numbers, contract number, weight, and dimension.

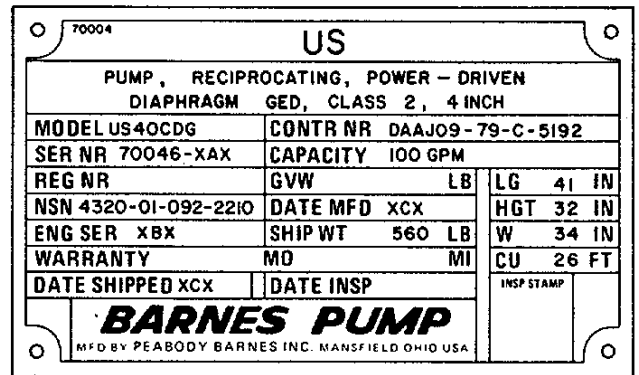

**1-11. EQUIPMENT DATA**

Manufacturer..... Peabody Barnes, Inc.  
 Model number..... US40CDG  
 Type ..... Self-priming diaphragm  
 Output (Maximum rated speed)  
     At 10 feet head ..... 100 gpm [38,400 phr] (378.5 L/m)  
     At 20 feet head ..... 66 gpm [25,344 phr] (249.81 L/m)  
 Rated speed  
     Engine . .....3600 rpm  
     Pump.....60 strokes per minute  
 Port size  
     Suction ..... 6 inches long, 4-inch NPT  
     Discharge ..... 6 inches long, 4-inch NPT  
 Engine  
     Manufacturer .....Military standard  
     Model number ..... 2A016  
     Type ..... Four stroke cycle  
     Horsepower..... 3  
     Cooling type . .....Air cooled  
     Lubricating oil . .....MIL-L-2104  
 Weight (Dry) ..... 560 lb (254 kg)

Section III. PRINCIPLES OF OPERATION

1-12. DIAPHRAGM PUMP

Consists of a gasoline engine and a wheel-mounted diaphragm pump. Power from the engine is transferred to the pump through a floating coupling, gear reducer, crank, and connecting rod.

- (A) ENGINE. Secured by engine mount to base assembly.
- (B) COUPLING GUARD. Serves as a safety device if coupling should shear.
- (C) FLOATING COUPLING. Connects engine drive shaft to gear reducer input shaft.
- (D) GEAR REDUCER. Serves as a speed reducer to transfer engine power to the pump.
- (E) CRANK. Fitted to the gear reducer output shaft to change the circular motion of the shaft to lift-and-force motion of the connecting rod.
- (F) CONNECTING ROD. Serves as the link between the crank and the pump diaphragm.
- (G) PUMP DIAPHRAGM. Changes the lift-and-force motion to suction and discharge pressure to move the water through the pump.
- (H) ACCUMULATOR. Serves as a reservoir to provide a constant flow of inlet water and to eliminate priming.
- (I) BYPASS VALVE ASSEMBLY. The suction side bypass valve assembly starts to open when the pump diaphragm begins the lift position and the discharge side bypass valve assembly starts to close. When the pump diaphragm starts moving to the force position, the suction side bypass assembly starts to close and the discharge side bypass valve assembly starts to open.
- (J) BOWL. Serves as the pump base to mount the diaphragm and bypass valve assemblies. Provides directional control of pumped water.
- (K) FRAME ASSEMBLY WITH DRAW BAR, ENGINE GUARD, AND WHEELS. Serves as a mobile support for all major assemblies.

1. Frame Assembly
2. Draw Bar
3. Engine Guard
4. Wheels

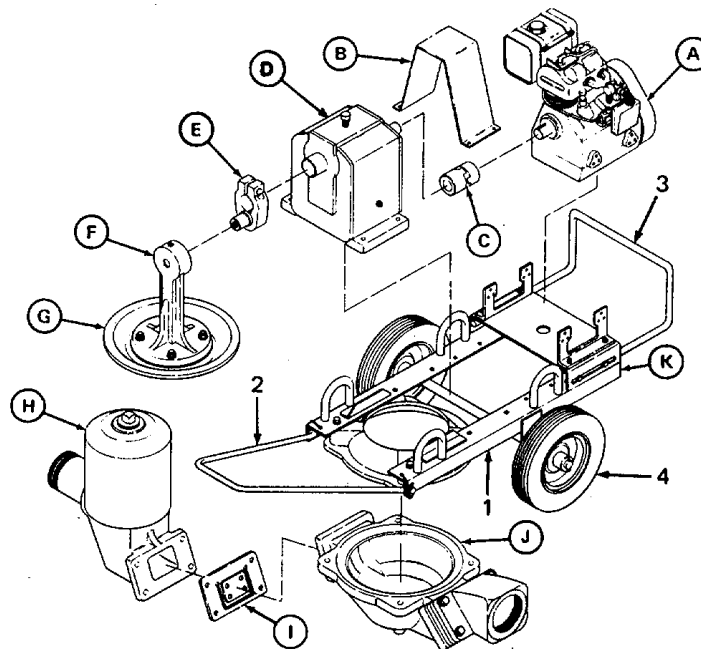



**CHAPTER 2**  
**OPERATING INSTRUCTIONS**

---

**Section I. DESCRIPTION AND USE OF OPERATOR'S CONTROLS AND INDICATORS**

**WARNING**

**Personal injury may result if the engine cutoff switch is not turned off during service or maintenance.**

The engine CUTOFF SWITCH attaches to the top of the engine and has two positions, OFF and ON. The switch controls the electrical current to the spark plug. In the ON position the electrical current will travel to the spark plug to run the engine. In the OFF position the electrical current will not travel to the spark plug and the engine will not start.

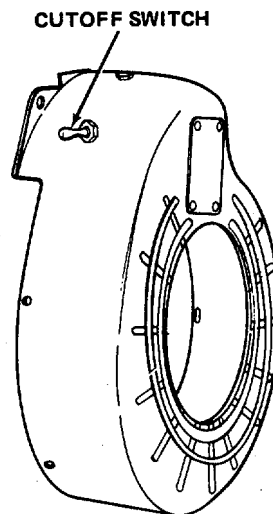

**Section II. OPERATOR/CREW PREVENTIVE MAINTENANCE CHECKS AND SERVICES (PMCS)**

**2-1. GENERAL**

- a. *Before you operate.* Always keep in mind the CAUTIONS and WARNINGS. Perform your before (B) PMCS.
- b. *While you operate.* Always keep in mind the CAUTIONS and WARNINGS. Perform your during (D) PMCS.
- c. *After you operate.* Be sure to perform your after (A) PMCS.
- d. *If your equipment fails to operate.* Troubleshoot with proper equipment. Report any deficiencies using the proper forms; see TM 38-750.

**2-2. PREVENTIVE MAINTENANCE CHECKS AND SERVICES**

Table 2-1 lists the preventive maintenance checks and services which shall be performed at specified intervals by the operator/crew.

**Table 2-1. Operator/Crew Preventive Maintenance Checks and Services**  
**B - Before                                  D - During                                  A - After**

Item No.	Interval			Item to be Inspected. Procedure	Equipment Is Not Ready Available If
	B	D	A		
1	•			<p><i>Engine Oil Level.</i> Check engine oil in accordance with LO 5-4320-275-02.</p> <p><i>Gear Reducer Oil Level.</i> Check oil in accordance with LO 5-4320-275-02.</p> <p><i>Fuel Filter.</i> Check for dirt or water in fuel filter. Turn shutoff valve in to OFF. Loosen nut on bail of fuel filter. Swing bail aside and remove fuel bowl. Dump fuel from bowl and wipe clean. Reposition fuel bowl and bail. Tighten nut on bail. Turn shutoff valve out to ON.</p> 	
2			•		
3			•		

Table 2-1. Operator/Crew Preventive Maintenance Checks and Services - Continued

Item No.	Interval			Item to be Inspected. Procedure	Equipment Is Not Ready Available If
	B	D	A		
4	•			<p><i>Wheels.</i> Check that cotter pin is securely holding wheel on axle. Replace if missing. Put cotter pin through hole in axle. Bend one end of cotter pin along contour of axle.</p> 	
5	•			<p><i>Draw Bar.</i> Check that hitch pins are in position through ends of draw bar.</p> 	
6		•		<p><i>Fuel System.</i> Check for loose lines and fittings. Tighten if necessary.</p>	<p>Fuel lines cannot be tightened to stop leaks.</p>

**Table 2-1. Operator/Crew Preventive Maintenance Checks and Services - Continued**  
**B - Before                                  D - During                                  A - After**

Item No.	Interval			Item to be Inspected. Procedure	Equipment Is Not Ready Available If
	B	D	A		
7	•			<p><i>Pump Assembly.</i> Check inlet and outlet pipe nipples for obstructions. Remove any dirt or debris clogging the pipe nipples.</p> 	<p>Water will not pass through pump for normal operation.</p>
8		•		<p><i>Check Valves.</i> Listen to operation of check valves. They must open and close during normal operation. If the check valves do not work properly, the pump will not pump water.</p>	<p>Check valves do not open and/or close.</p>
9	•			<p><i>Accumulator.</i> Check that pipe plug is on accumulator. Tighten pipe plug if it is loose.</p> 	<p>Pipe plug is missing.</p>

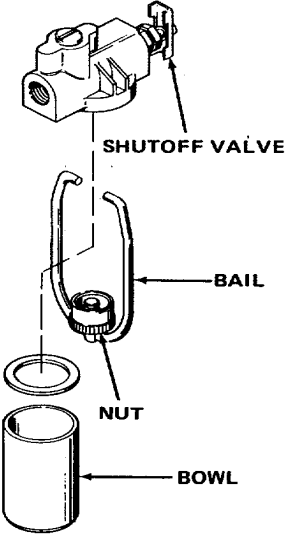
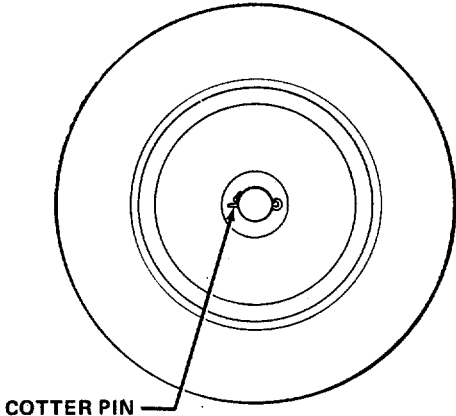
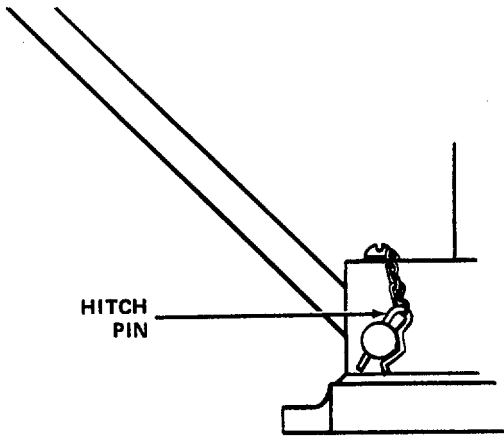
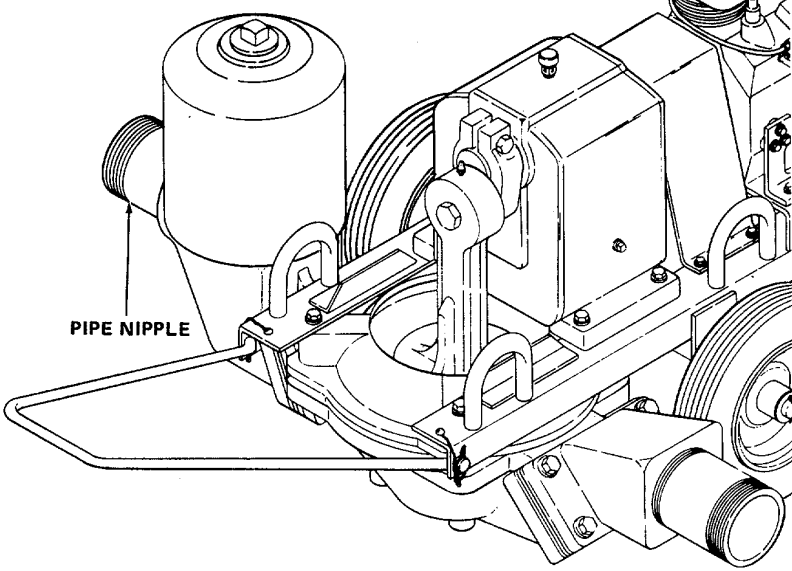
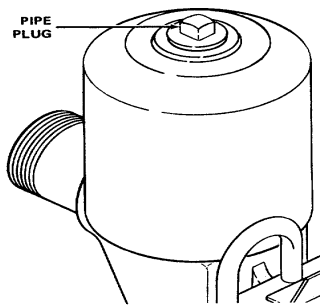

## 2-4. INITIAL ADJUSTMENTS

Inspect pump assembly and engine for loose or missing hardware, corrosion, or obvious damage. Report any problems to organizational maintenance.

## 2-5. OPERATING PROCEDURE

### a. *Selection and Preparation of Pump Site.*

- (1) Locate the pump on a level surface as close to the liquid supply as possible.
- (2) Block the wheels of the pump assembly to prevent the pump from shifting during operation.
- (3) When connecting suction hose to pump assembly, the suction lift of the pump must not exceed 25 feet (7.62 m).

### b. *Hose Installation.*

#### NOTE

**Use the shortest possible length of suction hose. Suction hose exceeding 20 feet (6.09 m) will reduce the pump capacity.**

- (1) Connect the suction hose to the accumulator pipe nipple. Use thread sealant on threaded connections. Tighten the suction hose with a spanner wrench NSN 5120-00-277-9077.

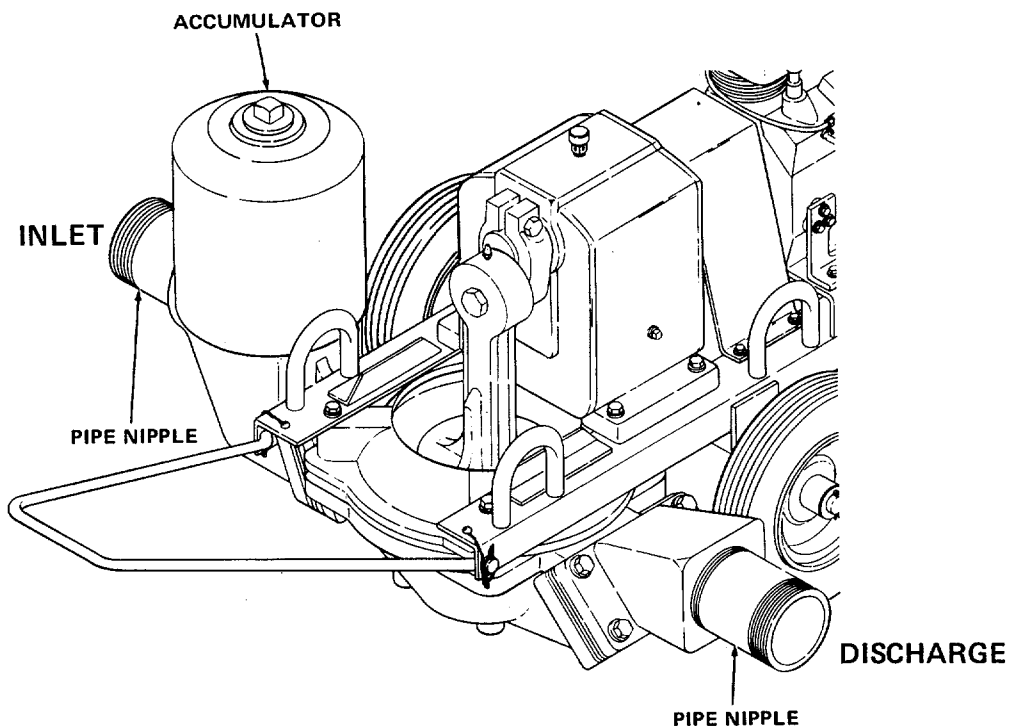

- (2) If more than one length of hose is required, add additional lengths to end of first hose attached to pump.

**CAUTION**

**Strainer NSN 4730-00-203-6309 must be used on the end of the suction hose to prevent rocks and other unbreakable material from entering the pump. These could cause severe damage to the pump.**

- (3) Connect a hose to the discharge pipe nipple of the pump. The length of the discharge hose shall not exceed 50 feet (15.24 m).
- (4) Make sure the end of the suction hose and strainer are completely submerged in the liquid to be pumped. Make sure the end of the discharge hose is free from any restrictions.

**2-6. STARTING****WARNING**

**Severe burns, illness, or death may result if personnel fail to handle gasoline properly. Observe the following precautions:**

- Do not inhale vapor.
  - Do not refuel a hot or running engine.
  - Do not refuel near open flame, sparks, or excessive heat.
  - Be certain fuel lines and connections are secure.
  - Do not overfill fuel tank.
  - Work in a well-ventilated area.
- a. Perform checks shown on operating procedure plate.
    - (1) Check engine oil level.
    - (2) Check gear box (gear reducer) oil.
    - (3) Has connecting rod been lubricated?
  - b. Fill fuel tank.

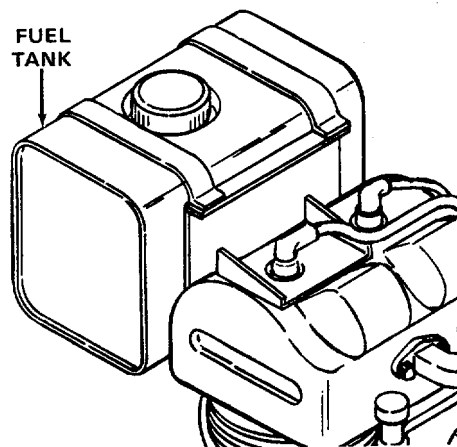

- c. Prime fuel system if engine is new or seldom-used.
  - (1) Turn engine cutoff switch to OFF position.
  - (2) Pull starting rope.
  - (3) Allow starting rope to retract.
  - (4) Pull starting rope again.
  - (5) Allow to retract.
- d. Turn engine cutoff switch ON.
- e. Pull starting rope sharply.
- f. Allow to retract.
- g. Repeat steps e. and f., if necessary, until engine starts. (Cold engines are harder to start.)
- h. If engine does not start after several attempts, see TROUBLESHOOTING PROCEDURES in Chapter 3 of this manual.

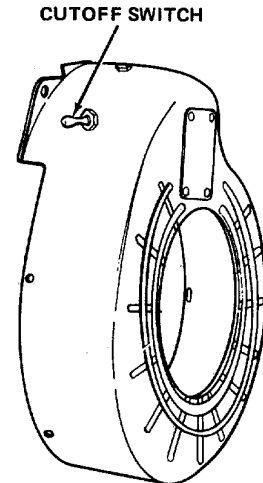

## 2-7. OPERATION

### NOTE

If the suction lift is less than 15 feet (4.57 m), pump priming is normally not necessary. If the suction lift is greater than 15 feet (4.57 m), use a 15/16 inch wrench to remove pipe plug from accumulator and pour 2 gallons (7.6 liters) of water into the accumulator to prime the pump. Install the pipe plug with a 15/16 inch wrench.

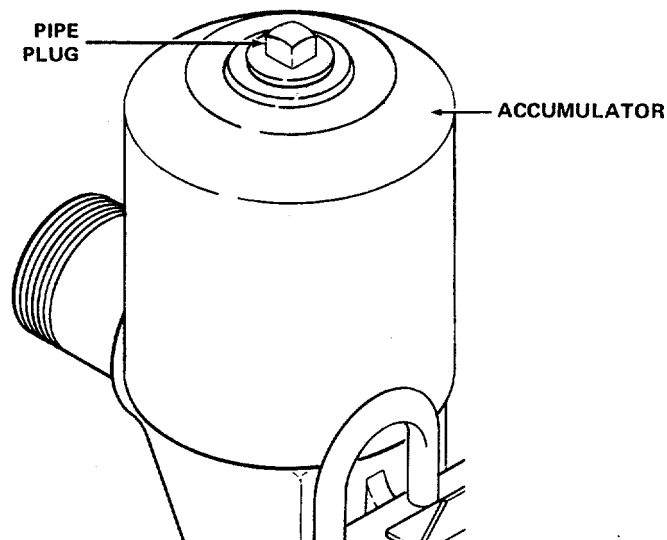

The pump should prime within 2 minutes after the engine starts. If the pump does not prime, see TROUBLESHOOTING PROCEDURES in Chapter 3 of this manual.



**2-8. STOPPING**

To stop pump, turn engine cutoff switch to OFF position.

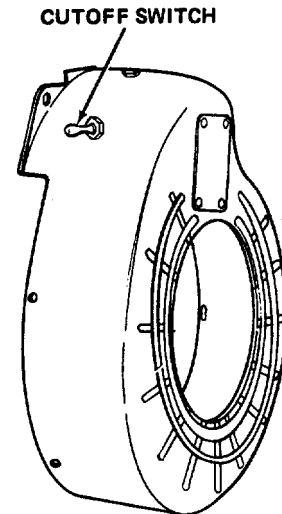

**2-9. MOVEMENT TO A NEW WORKSITE**

**CAUTION**

The wheels and axle of the pump assembly are designed to move the pump assembly into position at the worksite. They are not designed for use during road or highway movement of the pump assembly.

- a. Use a shipping dock or use wood planks as a ramp to load the pump assembly on the bed of a suitable truck to transport the pump assembly.
- b. Grasp the draw bar when moving the pump assembly.

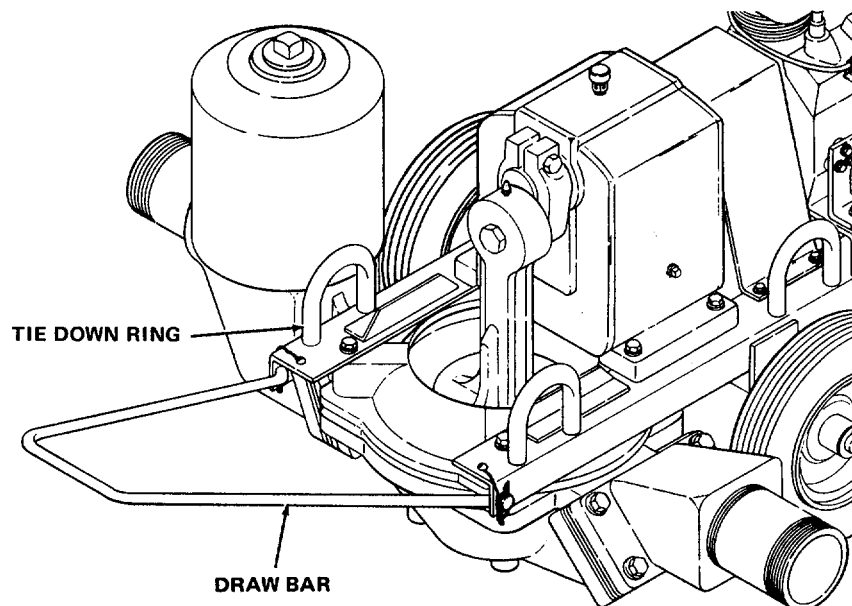

- c. Secure the pump assembly to the side of the truck to prevent it from shifting. Use the four tie down rings to secure the pump assembly. Lay the hoses on the bed of the truck.

**Section IV. OPERATION UNDER UNUSUAL CONDITIONS**

**2-10. OPERATION IN EXTREME COLD**

- a. Keep entire unit free of ice and snow.
- b. Cover unit when not in use.
- c. Shelter unit from weather, if possible.
- d. Use proper engine oil for cold weather. See LO 5-4320-275-12.
- e. Keep fuel tank full to prevent moisture condensation, which can freeze.
- f. Check and clean fuel filter before and after operating to prevent an accumulation of moisture, which can freeze.
  - (1) Turn shutoff valve in to OFF.
  - (2) Loosen nut on bail of fuel filter.
  - (3) Swing bail aside and remove fuel bowl.
  - (4) Dump fuel from bowl and wipe bowl.
  - (5) Reposition fuel bowl and bail.
  - (6) Tighten nut on bail.
  - (7) Turn shutoff valve out to ON.
- g. Drain pump after use to prevent water in pump from freezing.
  - (1) Remove drain plug from pump bowl.

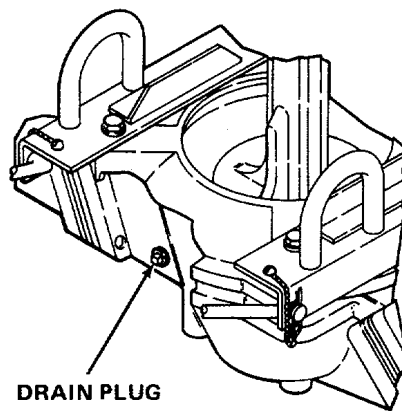
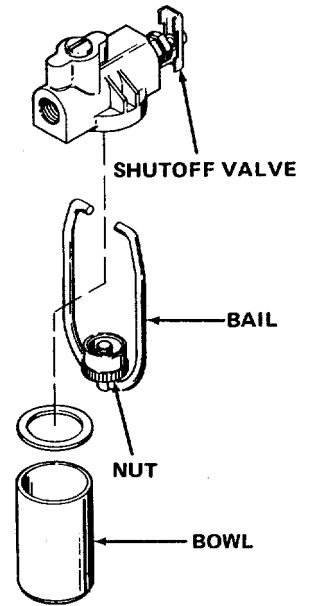

- (2) Turn engine cutoff switch to OFF position.

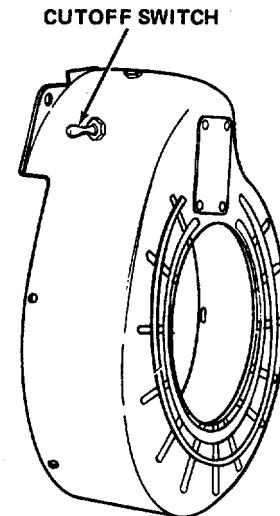

- (3) Pull starting rope sharply.
- (4) Allow to retract.
- (5) Repeat steps (3) and (4) above until all water is drained from pump bowl and accumulator.
- (6) Replace and tighten drain plug.

#### **2-11. OPERATION IN EXTREME HEAT**

- a. If possible, protect the pump assembly from direct rays of the sun.
- b. Allow adequate space for ventilation. If the pump is operated in an enclosure, use a fan to circulate air.
- c. Keep the engine shrouding and pump clean to provide proper heat transfer to the air.
- d. Check that lubricants in the engine comply with LO 5-4320-275-12.
- e. Although fluid flow can be stopped for short periods, avoid doing so in extreme heat for the fluid may boil in the pump bowl.

#### **2-12. OPERATION IN HIGH ALTITUDES**

The operating efficiency of both engine and pump diminishes at higher altitudes. Make sure that the engine is operating at peak efficiency, providing the highest possible pump output. Adjust in accordance with TM 5-2805-257-14.

#### **2-13. OPERATION IN SANDY OR DUSTY AREAS**

- a. When the pump is operated under sandy or dusty conditions, service engine air cleaner frequently in accordance with TM 5-2805-257-14.
- b. While filling the fuel tank, take care to prevent sand and dust from entering the fuel system.

c. Check fuel filter bowl for accumulations of dirt.

- (1) Turn shutoff valve in to OFF.
- (2) Loosen nut on bail of fuel filter.
- (3) Swing bail aside and remove fuel bowl.
- (4) Dump fuel from bowl and wipe bowl.
- (5) Reposition fuel bowl and bail.
- (6) Tighten nut on bail.
- (7) Turn shutoff valve out to ON.

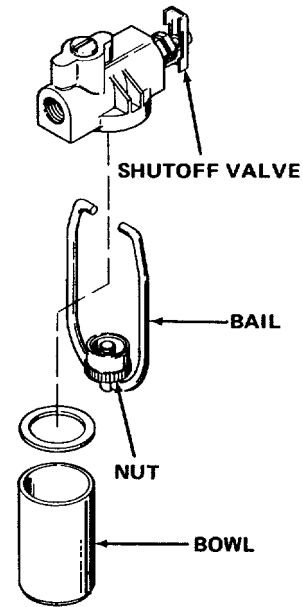

#### 2-14. OPERATION UNDER RAINY OR HUMID CONDITIONS

- a. Fill the fuel tank immediately after every operating period to prevent moisture in the air from condensing and entering the fuel system. Check the fuel filter bowl frequently for collection of moisture.
- b. Take special care to prevent rust and corrosion of exposed metal surfaces.

#### 2-15. OPERATION IN SALT WATER AREAS

- a. Salt water causes corrosion. Use fresh water to wash off any salt water that comes in contact with the equipment. This will help prevent the formation of rust and corrosion.
- b. Take special care to prevent rust and corrosion of exposed metal surfaces.

**CHAPTER 3  
OPERATOR/CREW MAINTENANCE INSTRUCTIONS**

---

**Section I. LUBRICATION INSTRUCTIONS**

No lubrication is authorized for operator/crew maintenance.

**Section II. TROUBLESHOOTING PROCEDURES**

**3-1. TROUBLESHOOTING**

a. Table 3-1 lists the common malfunctions which you may find during the operation or maintenance of the diaphragm pump or its components. Perform the tests/inspections and corrective actions in the order listed.

b. This manual cannot list all malfunctions that may occur, nor all tests or inspections and corrective actions. If a malfunction is not listed or is not corrected by listed corrective actions, notify your supervisor.

**Table 3-1. Operator/Crew Troubleshooting**

<b>MALFUNCTION</b>	<b>TEST OR INSPECTION</b>	<b>CORRECTIVE ACTION</b>
--------------------	---------------------------	--------------------------

**1. ENGINE FAILS TO START**

- Step 1.            Check for empty fuel tank.
- Fill fuel tank.

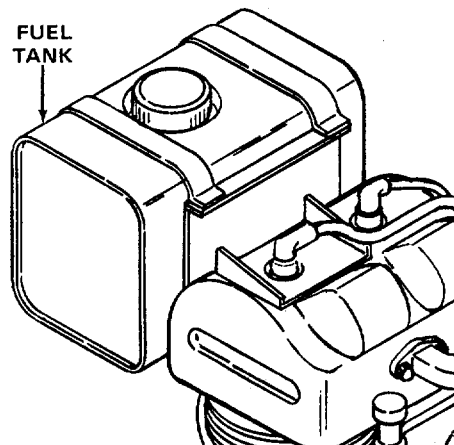
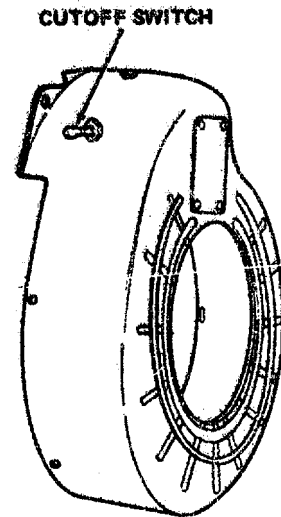

Table 3-1. Operator/Crew Troubleshooting

MALFUNCTION	TEST OR INSPECTION	CORRECTIVE ACTION
-------------	--------------------	-------------------

Step 2. Check for water in fuel.  
If water is present notify organizational maintenance.

Step 3. Turn engine cutoff switch to OFF position, Pull starting rope to prime fuel system. Turn cutoff switch to ON position and try to start engine.



Step 4. Check for moisture on spark plug or plug wire.  
Dry plug and wire, and try to start engine. Notify organizational maintenance of engine still does not start.

2. ENGINE STARTS BUT RUNS POORLY

Step 1. Check for water in fuel tank.  
If water is present notify organizational maintenance.

Step 2. Check for clogged fuel filter.  
If clogged notify organizational maintenance.

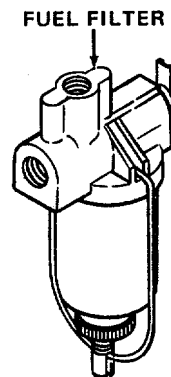
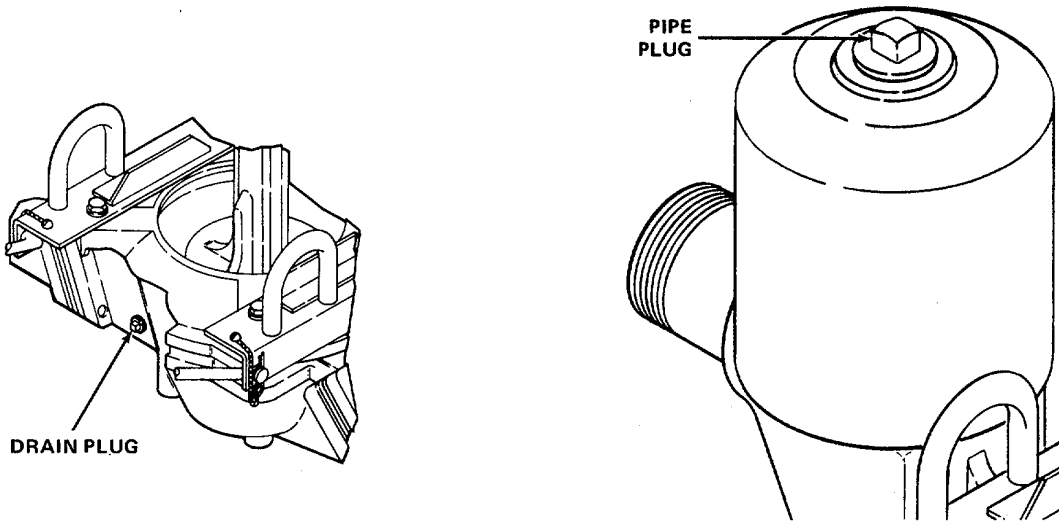

Table 3-1. Operator/Crew Troubleshooting - Continued

MALFUNCTION	TEST OR INSPECTION	CORRECTIVE ACTION
-------------	--------------------	-------------------

3. PUMP FAILS TO PRIME

- Step 1. Check for loose drain plug on pump bowl or pipe plug on accumulator.  
If clogged notify organizational maintenance.



- Step 2. Check for air leak at joint between accumulator and pump.  
If air leaks are present notify organizational maintenance.

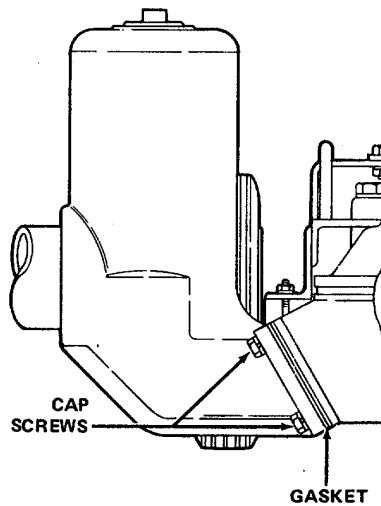

- Step 3. Check for air leak or blockage in suction line.  
If air leaks or blockage is present notify organizational maintenance.

**Section III. MAINTENANCE PROCEDURES**

**3-2. INTRODUCTION**

Operator/crew maintenance consists primarily of the following procedures:

- Checking pump and engine.
- Servicing fuel system.
- Cleaning pump assembly.

**3-3. CHECKING PUMP AND ENGINE**

Perform the visual and operational checks listed in table 3-2.

**Table 3-2. Operational Check**

Step	<p><b>Operation</b></p> <p><b>Normal Indication</b></p> <p><b>Corrective Procedure</b></p>
1	<p><b>Check fuel tank.</b>                      Tank should be full before operation.                      Fill fuel tank.</p> 
2	<p><b>Check for fuel leaks.</b>                      Fuel system should be free of leaks.                      Tighten any loose connections. Report leaking parts to organizational maintenance.</p>
3	<p><b>Check engine oil level when engine is hot.</b>                      Oil must be between FULL and ADD levels.                      Report low oil level to organizational maintenance.</p>
4	<p><b>Check air cleaner.</b>                      Must not be clogged or torn.                      Report clogged or damaged air cleaner to organizational maintenance.</p>



Table 3-2. Operational Checks - Continued

Step	<p><b>Operation</b></p> <p><b>Normal Indication</b></p> <p><b>Corrective Procedure</b></p>
5	<p><b>Check spark plug and wire.</b>                      Must be free of moisture and dirt.                      Wipe spark plug and wire clean and dry.</p>
6	<p><b>Check frame assembly for cracked welds, bad wheels, or loose parts.</b>                      Frame assembly should be free of defects.                      Tighten loose parts. Notify organizational maintenance for replacement or direct support for repair.</p>
7	<p><b>Check tire pressure.</b>                      Tire pressure should be 30 psi (207 kPa).                      Inflate tires.</p>
8	<p><b>Check pump hardware.</b>                      All hardware must be present and tight.                      Tighten loose hardware. Report missing hardware to organizational maintenance.</p>
9	<p><b>Check gear reducer for oil leaks.</b>                      No oil leaks.                      If oil leaks are present notify organizational maintenance.</p>
10	<p><b>Start engine.</b>                      Should run smoothly.                      If engine does not run smoothly, stop engine immediately. Notify organizational maintenance.</p>

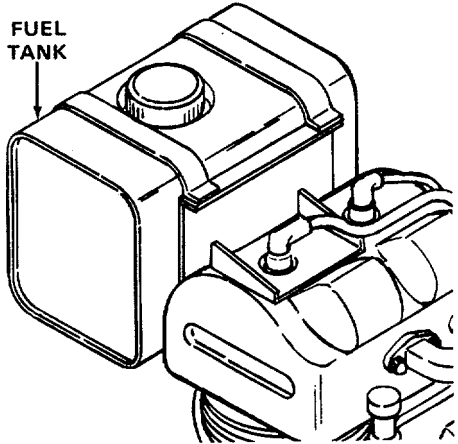
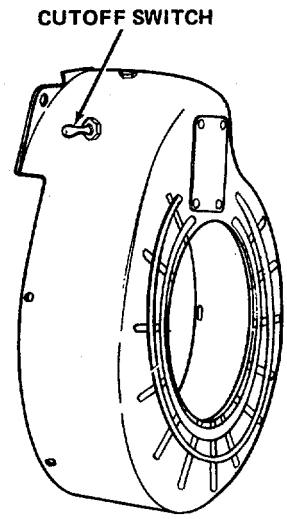

Table 3-2. Operational Checks - Continued

Step	Operation	Normal Indication	Corrective Procedure
	11	<b>Check for abnormal noises.</b>	Unit should run quietly and smoothly.
12	<b>Check drive operation.</b>	Operation should be smooth.	Report noisy operation to organizational maintenance.
13	<b>Check pump for leaks or rust.</b>	Pump should be free of leaks and rust.	Report leaks or rust condition to organizational maintenance.
14	<b>Check pump output.</b>	Fluid flow should be constant.	If flow is not constant, stop engine and clear pump inlet and outlet of obstacles.

### 3-4. SERVICING FUEL SYSTEM

Check and clean fuel filter before and after operating to prevent an accumulation of moisture, which can freeze.

- a. Turn shutoff valve in to OFF.
- b. Loosen nut on bail of fuel filter.
- c. Swing bail aside and remove fuel bowl.
- d. Dump fuel from bowl and wipe bowl.
- e. Reposition fuel bowl and bail.
- f. Tighten nut on bail.
- g. Turn shutoff valve out to ON.

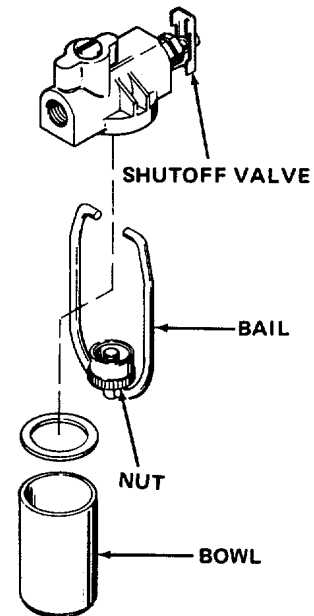

### 3-5. CLEANING

#### CAUTION

Because of the corrosive action of salt water, use fresh water to wash off any salt water that comes in contact with the equipment. This will help prevent the formation of rust and corrosion.

Before storing pump, clean inside and outside of pump with fresh water; wipe exterior dry.

3-7/(3-8 blank)

**CHAPTER 4**

**ORGANIZATIONAL MAINTENANCE INSTRUCTIONS**

This chapter contains the following frequently used maintenance information:

- a. Information on repair parts, special tools, TMDE, and support equipment
- b. Instructions for service upon receipt of the pump assembly
- c. Lubrication
- d. Operational checks
- e. Preventive maintenance checks and services (PMCS)
- f. Troubleshooting
- g. Maintenance procedures

The symptom index on page 4-14 is a guide to the troubleshooting information. There is also an index to the maintenance procedures on page 4-23.

Section	Title	Page
I	Repair Parts, Special Tools, TMDE, and Support Equipment.....	4-1
II	Service Upon Receipt.....	4-2
III	Operational Checks.....	4-5
IV	Preventive Maintenance Checks and Services.....	4-7
V	Troubleshooting.....	4-14
VI	Maintenance Procedures.....	4-23
VII	Preparation for Shipment or Storage.....	4-84

**Section I. REPAIR PARTS, SPECIAL TOOLS, TMDE, AND SUPPORT EQUIPMENT**

**4-1. COMMON TOOLS AND EQUIPMENT**

For authorized common tools and equipment, refer to the Modified Table of Organization and Equipment (MTOE) applicable to your unit.

**4-2. SPECIAL TOOLS, TMDE, AND SUPPORT EQUIPMENT**

No special tools, TMDE, or support equipment is required for this pump.

**4-3. REPAIR PARTS**

Repair parts are listed and illustrated in Appendix C of this manual.

**Section II. SERVICE UPON RECEIPT**

**4-4. SERVICE UPON RECEIPT OF MATERIEL- PUMP ASSEMBLY**

<b>Location</b>	<b>Item</b>	<b>Action</b>	<b>Remarks</b>
1. Top of engine	Fuel tank	Ensure tank is in good condition and not leaking.	
2. Side of engine	Fuel filter	Check that fuel filter is present and in good condition.	
3. Side of engine	Fuel lines	Check that fuel lines are present, in good condition, and secure.	
4. Top of engine	Cutoff switch	Check that switch is present and in good condition.	
5. Accumulator	Pipe plug	Check that pipe plug is present and secure.	
6. Bottom of	Drain plug	Check that drain plug is present and pump secure.	
7. Pump area	Check valves	Operate check valves by hand to be certain they open and close.	
8. Engine	Various	Refer to engine manual.	See TM 5-2805-257-14.

**4-5. SERVICING AND ADJUSTMENT OF EQUIPMENT**

a. *Preliminary.* No servicing or adjustment is required for the pump. Refer to TM 5-2805-257-14 for servicing and adjusting the engine.

b. *Lubrication.* Refer to LO 5-4320-275-12 (figure 4-1) for lubrication points, intervals, and detailed instructions.

LUBRICATION ORDER

# LO 5-4320-275-12

**PUMP, RECIPROCATING, POWER-DRIVEN,  
DIAPHRAGM, GASOLINE-ENGINE-DRIVEN,  
WHEEL MOUNTED**

**(US40CDG)  
4320-01-092-2210**

Reference: TM 5-4320-275-13 & P, C9100-IL

Intervals and the related man-hour times are based on normal operation. The man-hour time specified is the time required to perform all the services prescribed for a particular interval. The interval shall be changed to compensate for abnormal operation and severe operating conditions or contaminated lubricants. The interval may be extended during periods of low level activity, commensurate with adequate preservation precautions. Clean fittings

before lubricating. Clean parts with thinner, paint, volatile mineral spirits (EPM), or solvent, dry cleaning (SD). Dry before lubricating. Dotted arrow points indicate lubrication on both sides of the equipment. The lowest level of maintenance authorized to lubricate a point is Organizational Maintenance indicated by the symbol (O). Lubricate all chassis ports after washing or fording. Do not over-lubricate; wipe off excess.

FOLD

FOLD

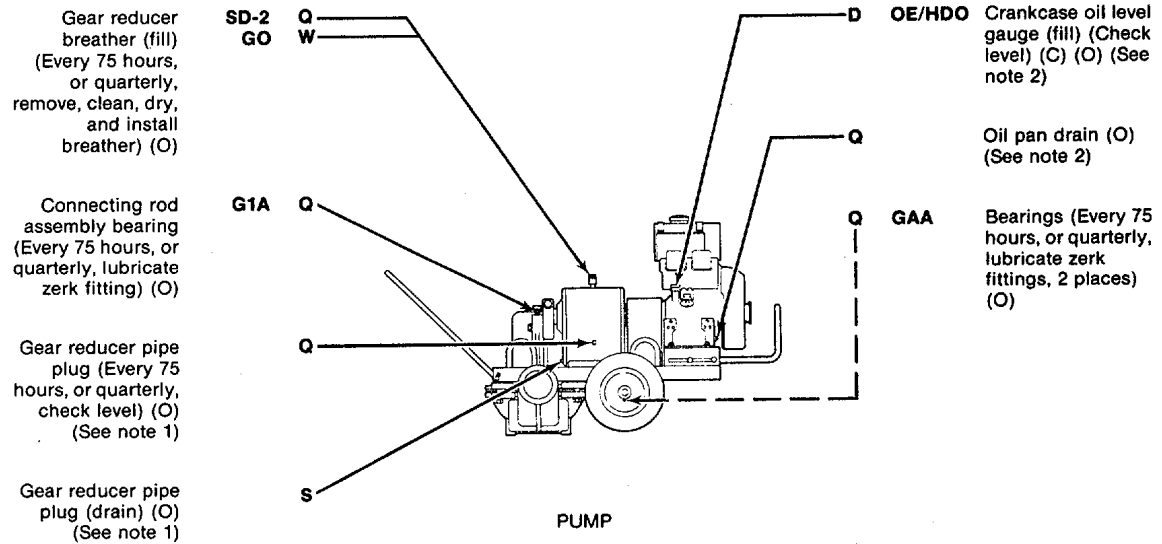

TOTAL MAN-HR		TOTAL MAN-HR	
INTERVAL	MAN-HR	INTERVAL	MAN-HR
D	0.1	Q	0.5
S	1.0	W	0.1

Figure 4-1. Lubrication Order (Sheet 1 of 2)

KEY				
LUBRICANT	EXPECTED TEMPERATURE			INTERVAL
	Above +32° F	+40° F to -10° F	0° F to -65° F	
<b>OE/HDO</b> - Lubricating oil, internal combustion engine, Grade 30 or 10 (Mil-L-2104, Grade 30 or 10) or <b>OES</b> - Differential final drive (Mil-L-10295)	<b>OE/HDO-30</b>	<b>OE/HDO-10</b>	<b>OES</b>	Q - Quarterly, or every 75 hours of operation A - Annually D - Daily  For arctic operation refer to TM9-207
<b>GAA</b> - Grease, automotive and artillery (Mil-G-10924)	All temperatures			
<b>G1A</b> - Grease, instrument, aircraft (Mil-G-23827)				
<b>SD-2</b> - Solvent, dry cleaning (P-D-680)				
<b>GO-90</b> - Lubricating oil, gear, multipurpose (Mil-L-2105, Grade 90)				
<b>OE-10</b> - Lubricating oil, internal combustion engine (Mil-L-2104, Grade 10)				

**NOTES**

1. GEAR REDUCER. -Sample oil weekly for contamination or breakdown, as indicated by discoloration, excessive foaming, and/or separation of lubricating components. If any of the above condi-

engine cool replenish oil, as required, using OE/HDO; reinstall level gauge. Every 150 hours, or semiannually, remove crankcase drain while the engine is hot and drain the oil. Inspect drain plug

FOLD

FOLD

tions is observed, change the oil as described below; if condition of lubricant is satisfactory, the interval between changes is semiannual and oil is changed as described below. Every 75 hours, or quarterly, remove breather and clean with solvent (SD-2), dry, and reinstall. Check level every 75 hours, or quarterly, and replenish as necessary using gear oil (GO-90); accomplish with oil cool. Semiannually, drain gear oil while oil is hot. Remove and inspect drain plug and drained oil for metal particles or fillings; if contaminants are found notify direct support maintenance personnel. Remove level plug and breather. After draining is complete install drain plug and fill unit to proper level with OE-10. Run unit for three minutes, if possible, and drain light oil from reducer by removing drain plug. Reinstall drain plug and tighten. Refill, through breather port, with oil (GO-90) until oil flows from level plug. Reinstall level plug and tighten. Reinstall breather and tighten.

and oil for metal particles or fillings; if contaminants are found notify direct support maintenance personnel. Install drain plug, and tighten. Fill oil pan with oil (OE/HDO or OES). See KEY above.

Copy of this lubrication order will remain with the equipment at all times; instructions contained herein are mandatory.

BY ORDER OF THE SECRETARY OF THE ARMY

General, United States Army,  
Chief of Staff.

OFFICIAL

The Adjutant General.

2. ENGINE CRANKCASE AND OIL PAN. -Check engine oil level daily; check with oil cool. With

Figure 4-1. Lubrication Order (Sheet 2 of 2)

Section III. OPERATIONAL CHECKS

4-6. OPERATIONAL CHECKS

Perform the visual and operational checks listed in table 4-1.

Table 4-1. Operational Checks

Step	<p>Operation</p> <p>Normal Indication</p> <p>Corrective Procedure</p>
1	<p><b>Check fuel tank.</b>                      Tank should be full before operation.                      Fill fuel tank.</p> 
2	<p><b>Check for fuel leaks.</b>                      Fuel system should be free of leaks.                      Tighten any loose connections. Replace leaking parts.</p>
3	<p><b>Check engine oil level when engine is hot.</b>                      Oil must be between FULL and ADD levels.                      Refer to LO 5-4320-275-12 (figure 4-1) to add oil.</p>
4	<p><b>Check engine air cleaner.</b>                      Must not be clogged or torn.                      See TM 5-2805-257-14 for replacement procedure.</p>
5	<p><b>Check spark plug and wire.</b>                      Must be free of moisture and dirt.                      Wipe spark plug and wire clean and dry.</p>



Table 4-1. Operational Checks - Continued

Step	<p><b>Operation</b></p> <p><b>Normal Indication</b></p> <p><b>Corrective Procedure</b></p>
6	<p><b>Check frame assembly for cracked welds, bad wheels, or loose parts.</b>                      Frame assembly and wheels should be free of defects.                      Tighten loose parts. Replace defective parts or send to direct support for repair.</p>
7	<p><b>Check tire pressure.</b>                      Tire pressure should be 30 psi (207 kPa).                      Inflate tires.</p>
8	<p><b>Check pump hardware.</b>                      All hardware must be present and tight.                      Install and/or tighten hardware.</p>
9	<p><b>Check gear reducer for oil leaks.</b>                      No oil leaks.                      Replace gear reducer or send to direct support for repair.</p>
10	<p><b>Start engine.</b>                      Should run smoothly.                      Stop engine immediately.                      See TM 5-2805-257-14.</p>
11	<p><b>Check for abnormal noises in engine.</b>                      Engine should run consistently.                      See TM 5-2805-257-14.</p>

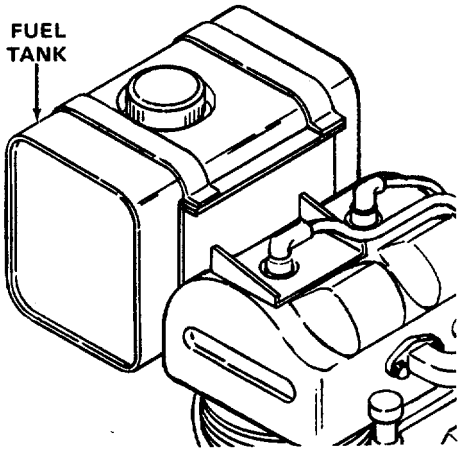
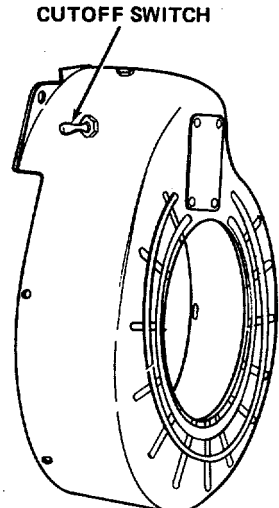

**Table 4-1. Operational Checks - Continued**

Step	Operation Normal Indication Corrective Procedure
12	<b>Check drive operation.</b> Operation should be smooth. Replace noisy parts.
13	<b>Check pump for leaks or rust.</b> Pump should be free of leaks and rust. Replace defective parts.
14	<b>Check pump output.</b> Pump should deliver approximately 100 gpm (38400 phr). Clear pump inlet and outlet of obstacles.

**Section IV. PREVENTIVE MAINTENANCE CHECKS AND SERVICES**

**4-7. PREVENTIVE MAINTENANCE CHECKS AND SERVICES**

Table 4-2 lists the preventive maintenance checks and services which shall be performed at specified intervals by organizational maintenance personnel. It includes and expands upon the preventive maintenance services performed by operator/crew maintenance and includes additional services which are allocated to organizational maintenance.

**NOTE**

Item numbers in the following table shall be used as source of item numbers for the TM Number Column on DA Form 2404, Equipment Inspection and Maintenance Worksheet, in recording results of PMCS.

Table 4-2. Organizational Preventive Maintenance Checks and Services

Item No.	Interval			Item to be Inspected	Procedures
	M	Q	S		
1	•			Engine oil.	Check that engine oil has been changed at required interval. See LO 5-4320-275-12 (figure 4-1).
2	•			Fuel system.	Check for leaks.
3	•			Fuel filter.	<p>Clean fuel filter. Turn shutoff valve in to OFF. Loosen nut on bail of fuel filter. Swing bail aside and remove fuel bowl. Dump fuel from bowl and wipe clean. Reposition fuel bowl and bail. Tighten nut or bail. Turn shutoff valve out to ON.</p> 
4	•			Wheels.	<p>Check that cotter pin is securely holding wheel on axle. Replace if missing. Put cotter pin through hole in axle. Bend one end of cotter pin along the contour of the axle.</p> 
5	•			Wheels.	Clean and check for damage. Check that wheel bearings have been lubricated in accordance with LO 5-4320-275-12 (figure 4-1).

Table 4-2. Organizational Preventive Maintenance Checks and Services - Continued

Item No.	Interval			Item to be Inspected	Procedures
	M	Q	S		
6	•			Tires.	Inspect tires for proper inflation and condition. Repair or replace tire assembly as necessary. Inflate tires to 30 psi (207 kPa).
7	•			Draw bar.	Check that hitch pins are in position through ends of draw bar.
8	•			Engine guard.	Check that cap screws holding engine guard to frame are tight.

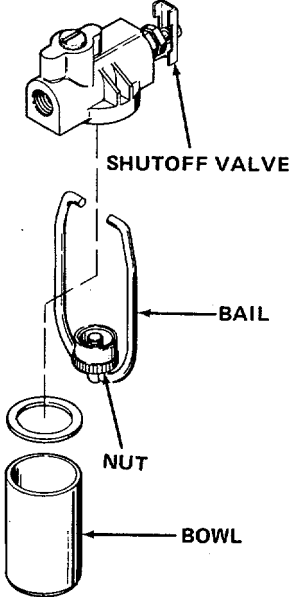
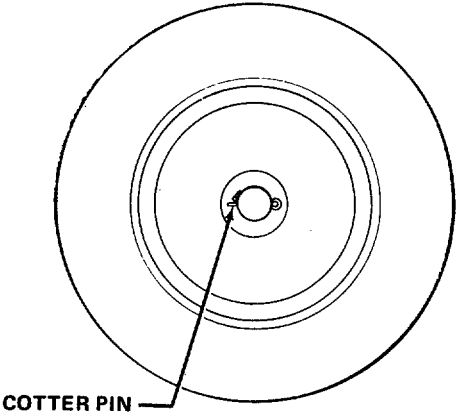
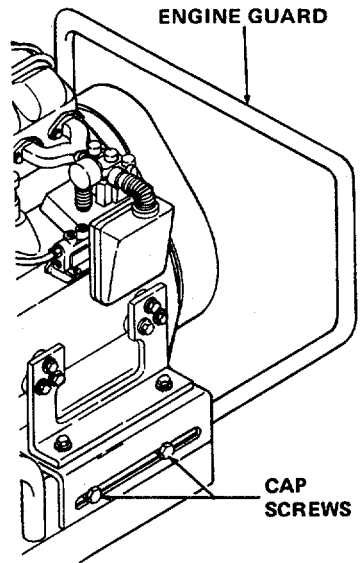
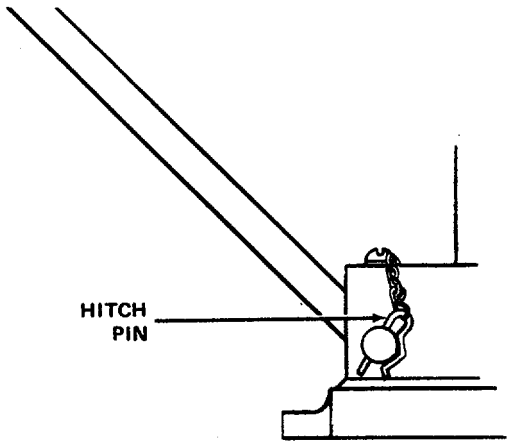

Table 4-2. Organizational Preventive Maintenance Checks and Services - Continued

Item No.	Interval			Item to be Inspected	Procedures
	M	Q	S		
9		•		Engine screws.	<p>Check that cap screws holding engine to engine mount are tight.</p> 
10			•	Frame assembly.	Check for cracks or broken welds.
11	•			Pump assembly.	<p>Check inlet and outlet pipe nipples for leaks, cracks, or damage. Replace any damaged pipe nipple.</p> 
12	•			Check valves.	<p>Start the engine and listen to the operation of the check valves. Check valves must open and close during normal operation. If check valves do not open and close, check for an obstruction in the accumulator or the discharge port, then</p>

Table 4-2. Organizational Preventive Maintenance Checks and Services - Continued

M - Monthly

Q - Quarterly

S - Semiannually

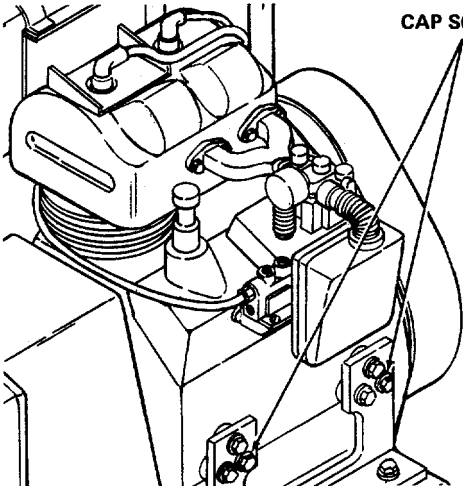
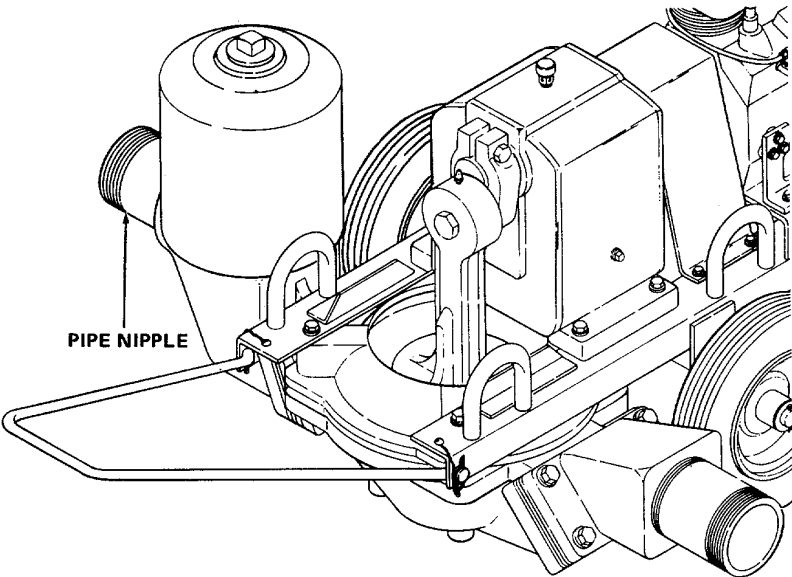
Item No.	Interval			Item to be Inspected	Procedures
	M	Q	S		
13	•			Accumulator.	<p>recheck. If one check valve does not operate properly, replace the check valve in accordance with paragraph 4-19 and 4-20. If both check valves do not operate properly, replace the diaphragm in accordance with paragraph 4-21. Check that pipe plug on accumulator is tight.</p> 
14	•			Pump bowl.	<p>Check that drain plug on pump bowl is tight.</p> 

Table 4-2. Organizational Preventive Maintenance Checks and Services - Continued

M - Monthly

Q - Quarterly

S - Semiannually

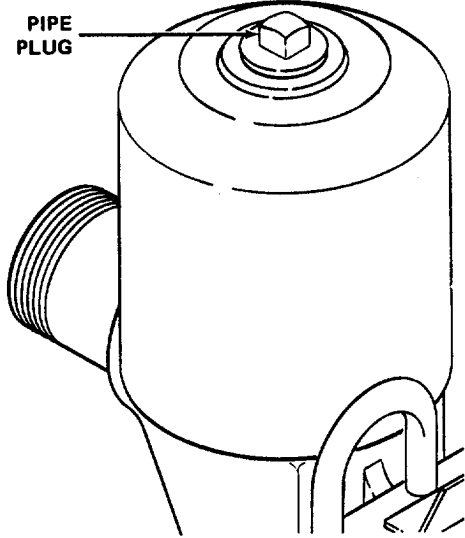
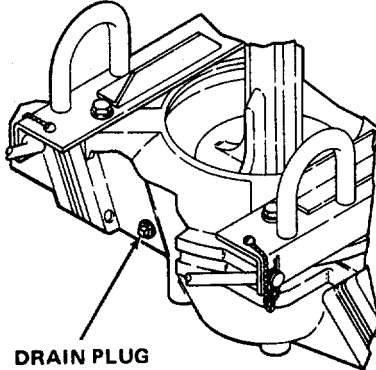
Item No.	Interval			Item to be Inspected	Procedures
	M	Q	S		
15				Pump screws.	<p>Check that cap screws holding pump to frame are tight.</p> 
16				Diaphragm clamp nuts.	<p>Check that nuts holding diaphragm between connecting rod assembly and clamp are tight.</p> 

Table 4-2. Organizational Preventive Maintenance Checks and Services - Continued

M - Monthly

Q - Quarterly

S - Semiannually

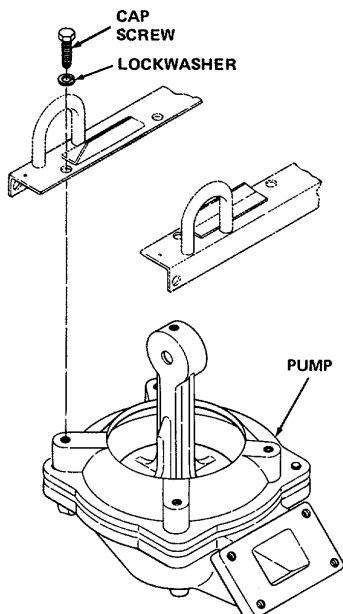
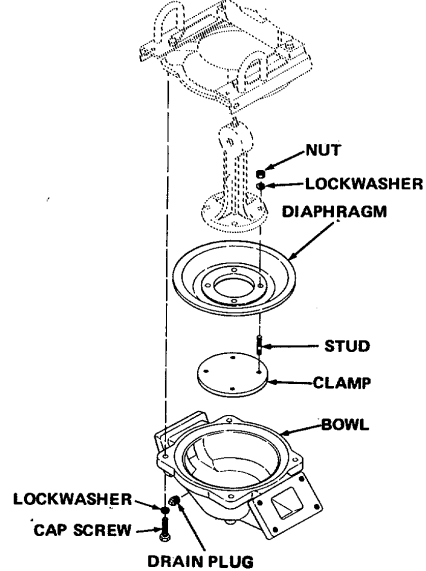
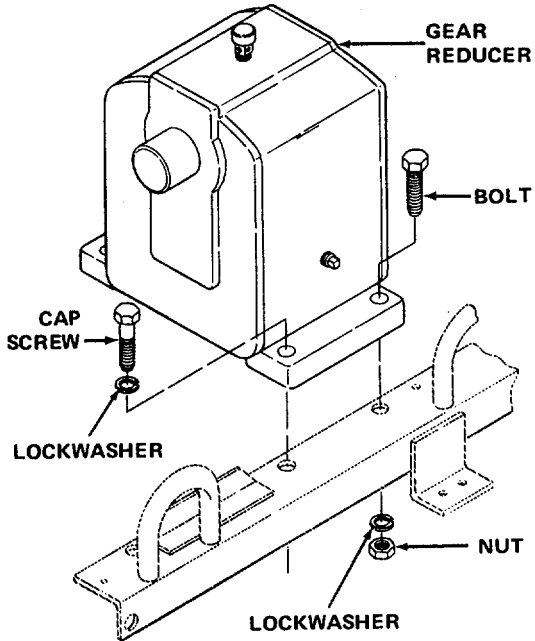
Item No.	Interval			Item to be Inspected	Procedures
	M	Q	S		
17	•			Diaphragm.	Check that diaphragm is not torn. Replace a torn diaphragm in accordance with paragraph 4-21.
18	•			Gear reducer	<p>Check that cap screws and nuts holding gear reducer to frame screws. are tight.</p> 
19	•			Gear reducer.	Check that gear reducer runs quietly and without restriction. Replace the gear reducer in accordance with paragraph 4-26 if it is noisy or if shaft rotation is restricted.
20	•			Gear reducer.	Check that gear reducer oil has been changed at required interval. See LO 5-4320-275-12 (figure 4-1).



**Section V. TROUBLESHOOTING**

**4-8. TROUBLESHOOTING**

a. Table 4-3 contains troubleshooting information for locating and correcting most of the operating troubles which are the responsibility of organizational maintenance. Each malfunction for an individual component, unit, or system is followed by a list of tests or inspections which will help you to determine probable causes and corrective actions to take. Perform the tests/inspections and corrective actions in the order listed.

b. This manual cannot list all malfunctions that may occur, nor all tests or inspections and corrective actions. If a malfunction is not listed or is not corrected by listed corrective actions, notify your supervisor.

c. Only those functions within the scope of organizational maintenance are listed. For troubleshooting procedures within the scope of operator/crew maintenance, refer to table 3-1.

**4-9. SYMPTOM INDEX**

Refer to the Symptom Index below. Locate the malfunction which is the same, or most nearly the same, as the trouble you are having with the pump. The Symptom Index lists the first page of troubleshooting information for that malfunction. Follow the steps one by one, and perform the corrective actions listed.

Malfunction Number	Description	Page
1	Engine fails to start	4-15
2	Engine starts, but stalls	4-18
3	Pump fails to prime, or has low output (engine running well)	4-21
4	Suction leak between accumulator and bowl	4-22

Table 4-3. Organizational Maintenance Troubleshooting

---

MALFUNCTION	TEST OR INSPECTION	CORRECTIVE ACTION
-------------	--------------------	-------------------

---

## 1. ENGINE FAILS TO START

Step 1. Check for empty fuel tank.

**WARNING**

- Allow engine to cool before filling with fuel.
- Perform maintenance outdoors or in a well-ventilated area to avoid illness caused by inhalation of fuel fumes.
- Severe burns, illness, or death can result from improper handling of gasoline.
- Do not inhale vapors.
- Do not work near open flame, sparks, or excessive heat.

Fill fuel tank.

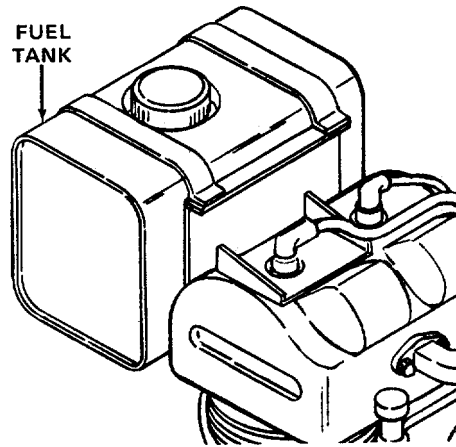

Table 4-3. Organizational Maintenance Troubleshooting - Continued

**MALFUNCTION**

**TEST OR INSPECTION**

**CORRECTIVE ACTION**

Step 2. Check for water or dirt in fuel filter bowl.

**WARNING**

- Allow engine to cool before draining fuel.
- Perform maintenance outdoors or in a well-ventilated area to avoid illness caused by inhalation of fuel fumes.
- Severe burns, illness, or death can result from improper handling of gasoline.
- Do not inhale vapors.
- Do not work near open flame, sparks, or excessive heat.

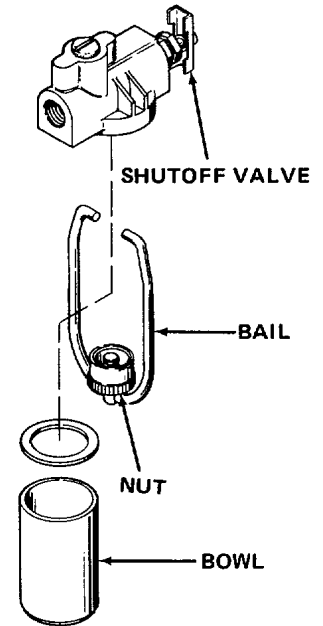

Turn shutoff valve in to OFF. Drain contents of fuel line into drain pan. Use 1/2 inch and 9/16 inch wrenches to remove fuel line from fitting on engine fuel pump. After draining, attach fuel line to fitting on engine fuel pump. Fill fuel tank with fresh fuel. Turn shutoff valve out to ON.

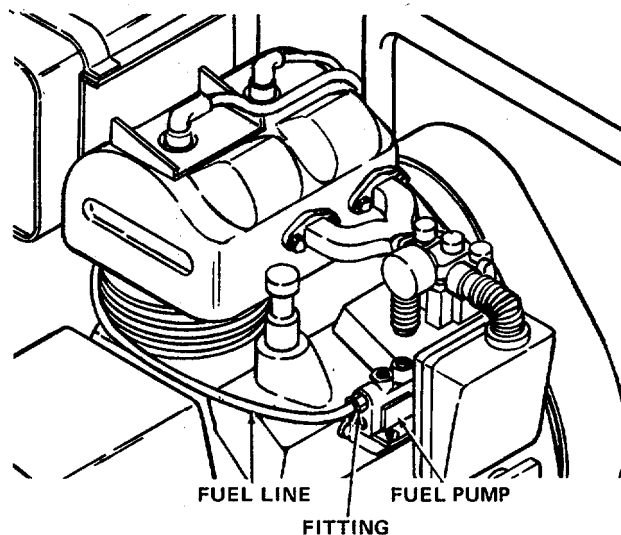

Table 4-3. Organizational Maintenance Troubleshooting - Continued

**MALFUNCTION****TEST OR INSPECTION****CORRECTIVE ACTION**

Step 3. Check for clogged fuel line.

**WARNING**

- Allow engine to cool before filling with fuel.
- Perform maintenance outdoors or in a well-ventilated area to avoid illness caused by inhalation of fuel fumes.
- Severe burns, illness, or death can result from improper handling of gasoline.
- Do not inhale vapors.
- Do not work near open flame, sparks, or excessive heat.

Turn shutoff valve in to OFF. Drain contents of fuel line into drain pan. Use 1/2 inch and 9/16 inch wrenches to remove fuel line from fitting on engine fuel pump. Use 1/2 inch wrench to remove fuel line from fuel filter. Remove clogged material from fuel line by gently probing with a blunt end rigid wire. If the clogging material cannot be removed, or if the fuel line is damaged, replace the fuel line. Use 1/2 inch wrench to attach fuel line to fuel filter. Attach fuel line to fitting on engine fuel pump. Turn shutoff valve out to ON.

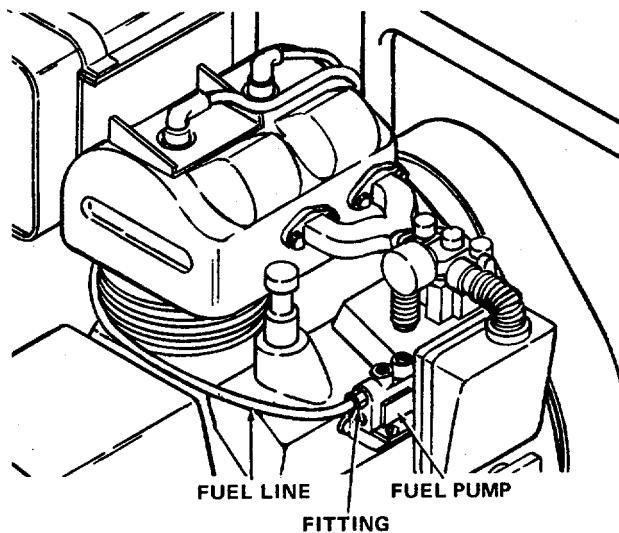

Table 4-3. Organizational Maintenance Troubleshooting - Continued

---

**MALFUNCTION****TEST OR INSPECTION****CORRECTIVE ACTION**

---

## 2. ENGINE STARTS, BUT STALLS

Step 1. Check for empty fuel tank.

**WARNING**

- Allow engine to cool before filling with fuel.
- Perform maintenance outdoors or in a well-ventilated area to avoid illness caused by inhalation of fuel fumes.
- Severe burns, illness, or death can result, from improper handling of gasoline.
- Do not inhale vapors.
- Do not work near open flame, sparks, or excessive heat.

Fill fuel tank.

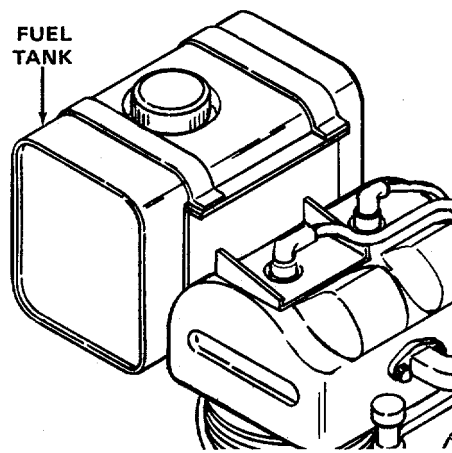

Table 4-3. Organizational Maintenance Troubleshooting - Continued

**MALFUNCTION**

**TEST OR INSPECTION**

**CORRECTIVE ACTION**

Step 2. Check for water or dirt in fuel filter bowl.

**WARNING**

- Allow engine to cool before draining fuel.
- Perform maintenance outdoors or in a well-ventilated area to avoid illness caused by inhalation of fuel fumes.
- Severe burns, illness, or death can result from improper handling of gasoline.
- Do not inhale vapors.
- Do not work near open flame, sparks, or excessive heat.

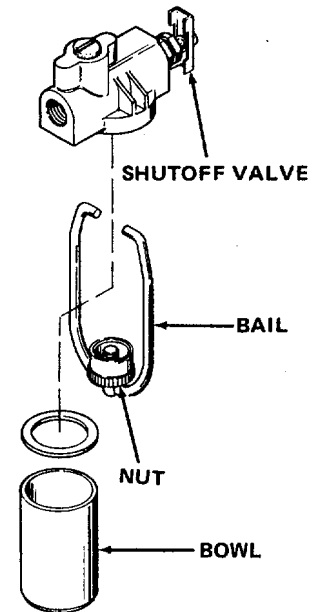

Turn shutoff valve in to OFF. Drain contents of fuel line into drain pan. Use 1/2 inch and 9/16 inch wrenches to remove fuel line from fitting on engine fuel pump. After draining, attach fuel line to fitting on engine fuel pump. Fill fuel tank with fresh fuel. Turn shutoff valve out to ON.

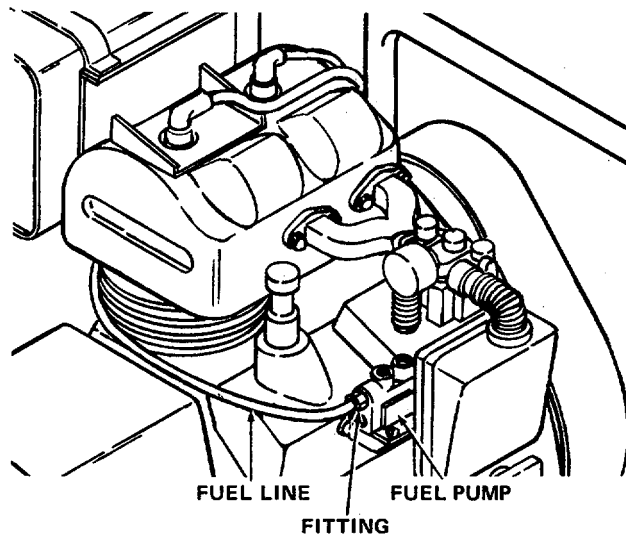

Table 4-3. Organizational Maintenance Troubleshooting - Continued

**MALFUNCTION****TEST OR INSPECTION****CORRECTIVE ACTION**

Step 3. Check for clogged fuel line.

**WARNING**

- **Allow engine to cool before filling with fuel.**
- **Perform maintenance outdoors or in a well-ventilated area to avoid illness caused by inhalation of fuel fumes.**
- **Severe burns, illness, or death can result from improper handling of gasoline.**
- **Do not inhale vapors.**
- **Do not work near open flame, sparks, or excessive heat.**

Turn shutoff valve in to OFF. Drain contents of fuel line into drain pan. Use 1/2 inch and 9/16 inch wrenches to remove fuel line from fitting on engine fuel pump. Use 1/2 inch wrench to remove fuel line from fuel filter. Remove clogged material from fuel line by gently probing with a blunt end rigid wire. If the clogging material cannot be removed, or if the fuel line is damaged, replace the fuel line. Use 1/2 inch wrench to attach fuel line to fuel filter. Attach fuel line to fitting on engine fuel pump.

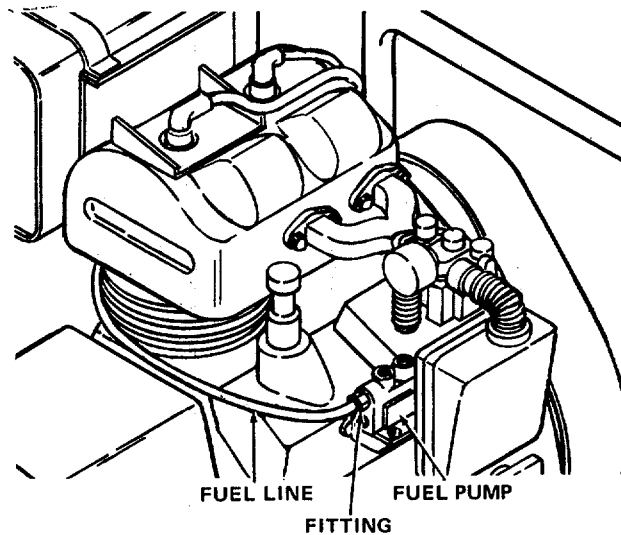

Table 4-3. Organizational Maintenance Troubleshooting - Continued

---

**MALFUNCTION****TEST OR INSPECTION****CORRECTIVE ACTION**

---

## 3. PUMP FAILS TO PRIME, OR HAS LOW OUTPUT (ENGINE RUNNING WELL)

- Step 1. Check for loose drain plug on bowl.  
Use 5/8 inch wrench to tighten drain plug.

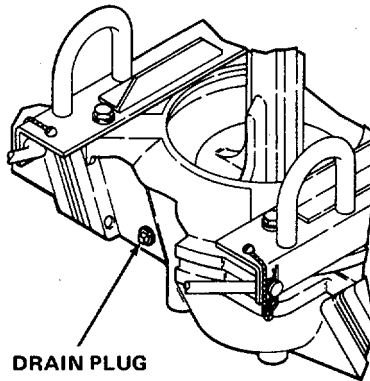

- Step 2. Check for loose pipe plug on accumulator.

Use 1-1/4 inch wrench to tighten pipe plug.

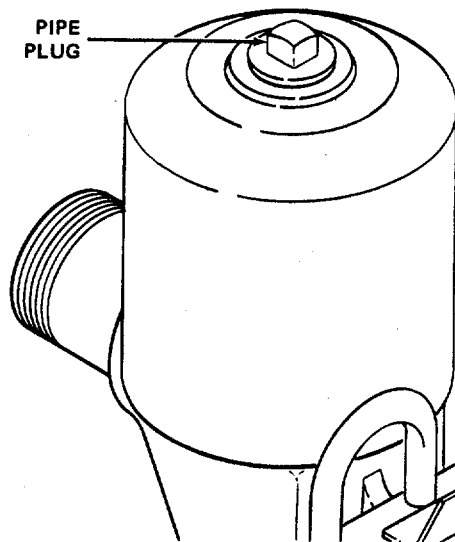



Table 4-3. Organizational Maintenance Troubleshooting - Continued

**MALFUNCTION**

**TEST OR INSPECTION**

**CORRECTIVE ACTION**

Step 3. Check for leaks in suction hose by inspecting all parts of suction hose for cracks or other damage.

Replace damaged suction hose. Tighten suction hose on accumulator pipe nipple.

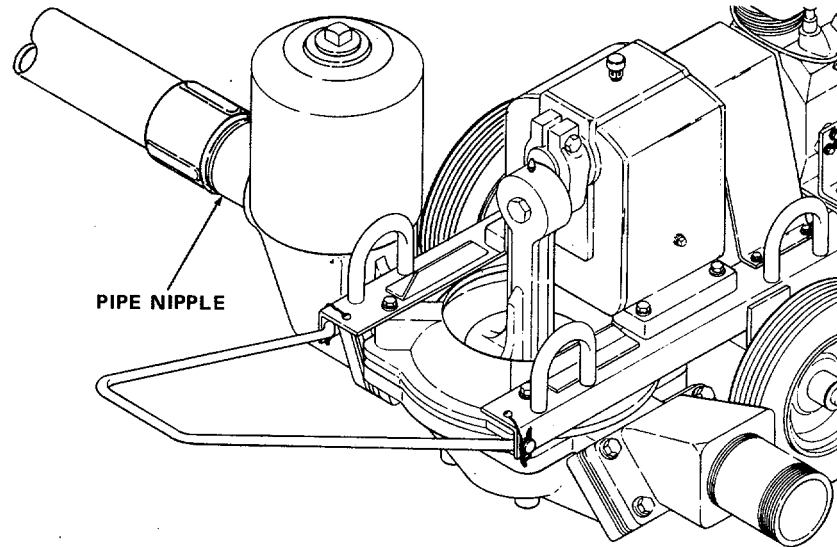

**4. SUCTION LEAK BETWEEN ACCUMULATOR AND BOWL**

Step 1. Check for loose screws holding accumulator on bowl.

Tighten cap screws. Use 3/4 inch socket with a torque wrench and tighten the four cap screws to a torque of 40 ft lb (54 N•m).

Step 2. Check for bad gasket between accumulator and check valve assembly.

Replace gasket. Use 3/4 inch socket and handle to remove four cap screws holding accumulator on bowl. Remove accumulator and gasket. Install new gasket between accumulator and check valve assembly. Use 3/4 inch socket with a torque wrench and tighten the four cap screws to a torque of 40 ft lb (54 N•m). Use Loctite (Item 7, Appendix D) on threads.

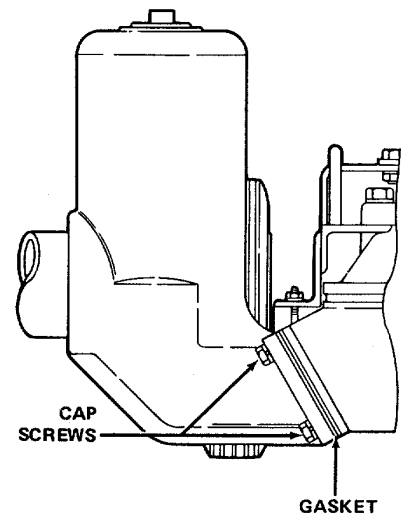

Table 4-3. Organizational Maintenance Troubleshooting - Continued

**MALFUNCTION**

**TEST OR INSPECTION**

**CORRECTIVE ACTION**

Step 3. Check for defective check valve assembly on accumulator side of bowl.

Replace check valve assembly. Use 3/4 inch socket and handle to remove four cap screws holding accumulator on bowl. Remove accumulator, gasket, and check valve assembly. Install a new gasket and check valve assembly. Use 3/4 inch socket with a torque wrench and tighten the four cap screws to a torque of 40 ft lb (54 N.m). Use Loctite (Item 7, Appendix D) on threads.

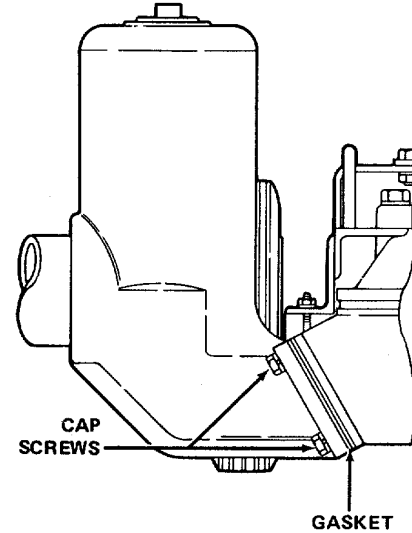

**Section VI. MAINTENANCE PROCEDURES**

**INDEX**

	Para		Para
Accumulator	4-19	Gear reducer	4-26
Axle	4-16	Identification plate	4-18
Bowl, pump	4-23	Inspection	4-11
Clamp assembly	4-22	Operating plate	4-18
Connecting rod assembly	4-24	Plates, data	4-18
Coupling	4-25	Port, discharge	4-20
Data plates	4-18	Pump bowl	4-23
Diaphragm	4-21	Reducer, gear	4-26
Discharge port	4-20	Rod assembly, connecting	4-24
Engine	4-12	Strainer, fuel	4-14
Filter, fuel	4-13	Tires	4-17
Frame assembly	4-16	Tubes, inner	4-17
Fuel		U-bolts	4-16
Filter	4-13	Wheel assembly	4-17
Line	4-15		
Strainer	4-14		
Tank	4-14		

**4-10. GENERAL INSTRUCTIONS**

Most maintenance instructions in this section will list resources required, personnel required, and equipment condition for the start of the procedure. Note the following:

- Resources required are not listed unless they apply to the procedure.
- Personnel required are listed only if the task requires more than one. If PERSONNEL is not listed, it means one person can do the task.
- The normal standard equipment condition to start a maintenance task is engine stopped and cutoff switch off. EQUIPMENT CONDITION is not listed unless some other condition is required besides the power being off.

**4-11. PUMP ASSEMBLY INSPECTION**

Component	Acceptable	Repairable	Not Repairable
Engine	Attaching screws tight.	Loose screws.	Stripped screw holes.
Fuel filter	Clean.	Dirty.	Stripped threads or broken.
Fuel tank	No leaks.	Replace tank.	None.
Fuel line	No leaks.	Tighten fuel lines.	Leak in fuel line.
Wheel assembly	Tight. No air leaks.	Replace leaking tires.	None.
Frame assembly	No cracks.	None.	---
Data plates	Legible. Tight.	Replace.	---
Accumulator	No leaks.	Replace gasket.	Crack in accumulator.
Pipe plug	Tight. No leaks.	Tighten pipe plug.	---
Check valve assembly	No leaks. Operable.	Replace valve assembly.	None.
Bowl pipe plug	Tight. No leaks.	Tighten pipe plug.	---
Diaphragm	No leaks.	Replace diaphragm.	None.
Discharge port	No leaks.	Replace gasket.	Crack in discharge port.
Clamp assembly studs.	Tight.	Loose nuts.	Stripped threads on
Connecting rod assembly	Tight.	Loose shoulder bolt.	Bent or cracked rod.
Coupling	Minimal backlash.	Replace coupling.	None.
Gear reducer	No binding.	Replace gear reducer.	None.

---

**4-12. ENGINE**

---

This task covers:

- a. Shutting off fuel supply to engine
  - b. Removing engine
  - c. Installing engine
- 

**INITIAL SETUP****Test Equipment**

None

**Tools**

Tool kit, general mechanics automotive,  
NSN 5180-00-177-7033

Wrench, 7/16 inch, or  
Socket, 7/16 inch and handle  
Wrench, 9/16 inch, or  
Socket, 9/16 inch and handle  
Key, hex drive, 5/32 inch  
Puller, mechanical, gear and bearing

Shop equipment, automotive  
maintenance and repair,  
NSN 4910-00-754-0654

Torque wrench, 0-175 ft lb  
(0-250 N•m)

**Materials/Parts**

Gasoline engine (Appendix C, item 3, fig. 1)  
Fuel tank assembly (Appendix C, item 4, fig. 2)  
Key (Appendix C, item 20, fig. 8)  
Loctite (Item 7, Appendix D)

**Personnel Required: 2**

Mechanic will assist in lifting engine.

**References**

None

**Troubleshooting References**

None

**Special Environmental Conditions**

Well-ventilated area required when  
gasoline is handled.

**General Safety Instructions**

Allow engine to cool before performing  
any maintenance.

---

**ENGINE (CONT)**

LOCATION/ITEM	ACTION	REMARKS
---------------	--------	---------

**REMOVAL**

**WARNING**

Severe burns, illness, or death can result from improper handling of gasoline. When working with gasoline:

- .. Do not inhale vapors.
- .. Work in well-ventilated area.
- .. Do not work near open flame, sparks, or excessive heat.

- |                |                               |
|----------------|-------------------------------|
| 1. Fuel filter | Turn shutoff valve in to OFF. |
|----------------|-------------------------------|

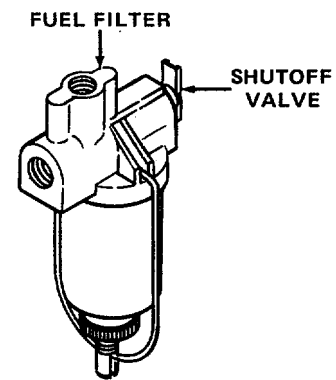

- |                 |  |
|-----------------|--|
| 2. Engine guard | Loosen 4 cap screws (1) with 9/16 inch wrench. Pull engine guard (2) away from engine. |
|-----------------|--|

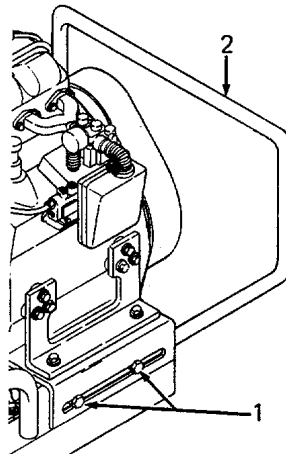

**ENGINE (CONT)**

LOCATION/ITEM	ACTION	REMARKS
---------------	--------	---------

3. Coupling guard

Use 7/16 inch socket and handle to remove 4 cap screws (1) and lockwashers (3). Hold nut (2) with 7/16 inch wrench. Remove coupling guard (4) by lifting straight up.

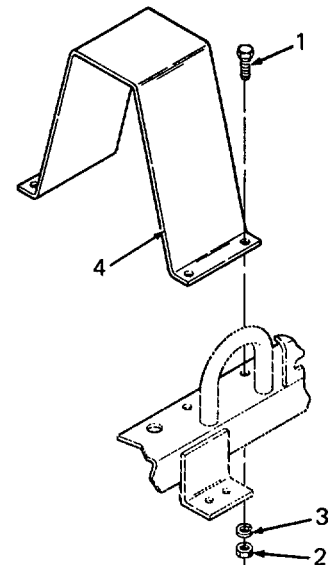

4. Engine

Use 7/16 inch wrench to remove 12 cap screws (1) and lockwashers (2) from engine (6). Slide engine away from gear reducer (3). Use a 5/32 inch hex key to loosen set-screw in engine coupling (4) half. Remove coupling half from engine. Remove and discard key (5). Lift engine (6) off frame (7).

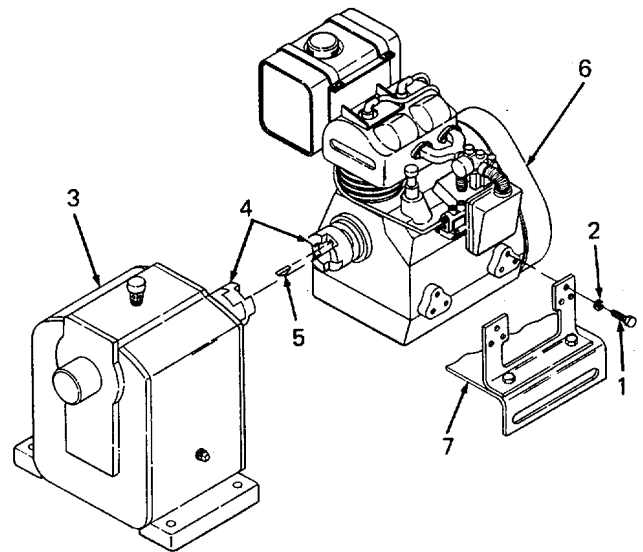

**NOTE**

It may be necessary to use a mechanical gear and bearing, puller to remove coupling half from engine.

**ENGINE (CONT)**

LOCATION/ITEM	ACTION	REMARKS
---------------	--------	---------

**DISASSEMBLY**

5. Engine This manual contains no engine disassembly instructions. See TM 5-2805-257-14 for engine disassembly.

**CLEANING**

6. Engine This manual contains no engine cleaning instructions. See TM 5-2805-257-14 for engine cleaning.

**INSTALLATION**

7. Engine Install new key (5) in engine shaft groove. Install half of coupling (4) onto key (5) and engine shaft. Use a 5/32 inch hex key to tighten setscrew on coupling (4). Slide engine (6) toward gear reducer (3) and align coupling halves.

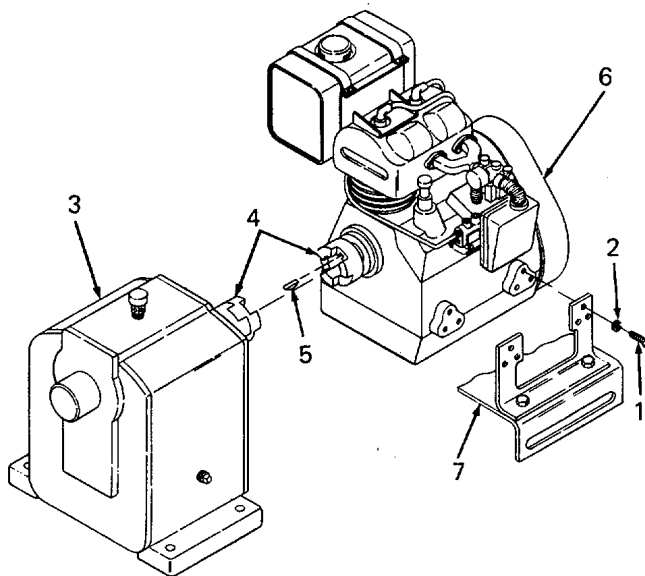

8. Torque cap screws Install lockwashers (2) on cap screws (1). Use Loctite on threads. Tighten 12 cap screws to 4 ft lb (5 N•m).

**ENGINE (CONT)**

LOCATION/ITEM	ACTION	REMARKS
9. Coupling guard	Position coupling guard (4) over coupling and align holes with frame holes. Install 4 cap screws (1), lockwashers (3), and nuts (2). Use Loctite on threads. Hold nuts (2) with 7/16 inch wrench and tighten cap screws (1) with 7/16 inch socket and handle.	
10. Engine guard	Slide engine guard (2) toward engine. Position engine guard so it is clear of engine starting pulley. Tighten cap screws (1).	
11. Torque cap screws	Tighten 4 cap screws (1) to 4 ft lb (5 N•m).	
12. Fuel filter	Turn shutoff valve out to ON.	



**4-13. FUEL FILTER**

This task covers:

- |  |  |
|--|--|
| <ul style="list-style-type: none"> <li>a. Shutting off fuel supply.</li> <li>c. Cleaning fuel filter.</li> </ul> | <ul style="list-style-type: none"> <li>b. Disassembling fuel filter.</li> <li>d. Assembling fuel filter</li> </ul> |
|--|--|

**INITIAL SETUP**

**Test Equipment**

None

**Tools**

None

**Materials/Parts**

Fuel filter (Appendix C, item 15, fig. 2)

Dry cleaning solvent, P-D-680

**References**

None

**Troubleshooting References**

Malfunction 1, step 2

Malfunction 2, step 2

**Special Environmental Conditions**

Well-ventilated area required when gasoline or solvent is handled.

**General Safety Instructions**

None

**FUEL FILTER (CONT)**

LOCATION/ITEM	ACTION	REMARKS
---------------	--------	---------

**DISASSEMBLY**

**WARNING**

Severe burns, illness, or death can result from improper handling of gasoline. When working with gasoline:

- Do not inhale vapors.
- Work in well-ventilated area.
- Do not work near open flame, sparks, or excessive heat.

- |                  |  |
|------------------|--|
| 1. Shutoff valve | Turn shutoff valve (1) in to OFF.              |
| 2. Nut           | Loosen nut (2) on bail.                        |
| 3. Bail and bowl | Swing bail (3) aside and remove fuel bowl (4). |

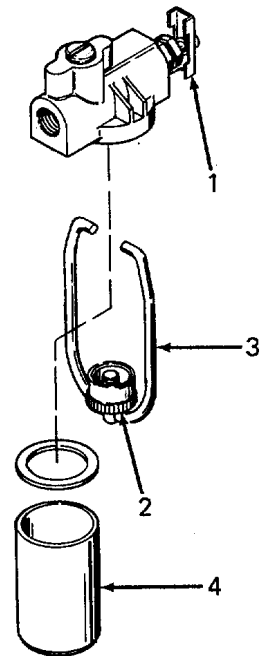

**CLEANING**

**WARNING**

Clean parts in a well-ventilated area. Avoid inhalation of solvent fumes and prolonged exposure of skin to cleaning solvent. Wash exposed skin thoroughly. Dry cleaning solvent (fed. spec. P-D-680) used to clean parts is potentially dangerous to personnel and property. Do not use near open flame or excessive heat. Flash point of solvent is 100° F (38° C).

- |         |  |
|---------|--|
| 4. Bowl | Clean inside of bowl with dry cleaning solvent, P-D-680, and wipe dry. |
|---------|--|

**FUEL FILTER (CONT)**

LOCATION/ITEM	ACTION	REMARKS
5. Exterior of fuel filter	Clean outside of fuel filter with dry cleaning solvent, P-D-680. Use a soft-bristle brush to remove caked dirt.	

**ASSEMBLY**

**CAUTION**

**Be certain top of bowl is clean of any foreign material when assembling on fuel filter.**

- |                  |  |
|------------------|--|
| 6. Bowl and bail | Set bowl (4) on fuel filter and swing bail (3) to hold bowl. |
| 7. Nut           | Tighten nut (2) on bail.                                     |
| 8. Shutoff valve | Turn shutoff valve (1) out to ON.                            |

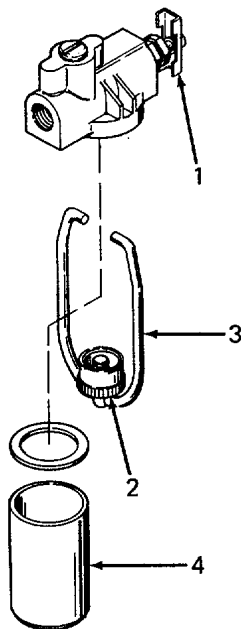

---

**4-14. FUEL TANK**

---

This task covers:

- |                         |                         |
|-------------------------|-------------------------|
| a. Draining fuel tank   | b. Removing fuel tank   |
| c. Strainer replacement | d. Installing fuel tank |
- 

**INITIAL SETUP****Test Equipment**

None

**Tools**

Tool kit, general mechanics automotive,  
NSN 5180-00-177-7033

Screwdriver, flat tip  
Wrench, 7/16 inch  
Wrench, 3/8 inch, or  
Socket, 3/8 inch, and handle  
Wrench, 1/2 inch  
Wrench, 9/16 inch  
Drain pan

**Materials/Parts**

Fuel tank (Appendix C, item 4, fig  
Loctite (Item 7, Appendix D)

**References**

None

**Troubleshooting References**

None

**Equipment Condition**

Fuel filter shutoff valve OFF.

**Special Environmental Conditions**

Well-ventilated area required when gasoline  
is handled.

**General Safety Instructions****WARNING**

- Be certain fuel tank is empty before removing from engine.
  - Allow engine to cool before performing any maintenance.
  - Perform maintenance outdoors or in a well-ventilated area to avoid illness caused by inhalation of fuel fumes.
-

**FUEL TANK (CONT)**

LOCATION/ITEM	ACTION	REMARKS
---------------	--------	---------

**REMOVAL**

**WARNING**

Severe burns, illness, or death can result from improper handling of gasoline. When working with gasoline:

- Do not inhale vapors.
- Work in well-ventilated area.
- Do not work near open flame, sparks, or excessive heat.

- |    |           |   |
|----|-----------|---|
| 1. | Pipe plug | Drain contents of fuel tank into drain pan. Use 7/16 inch wrench to remove pipe plug. |
|----|-----------|---|

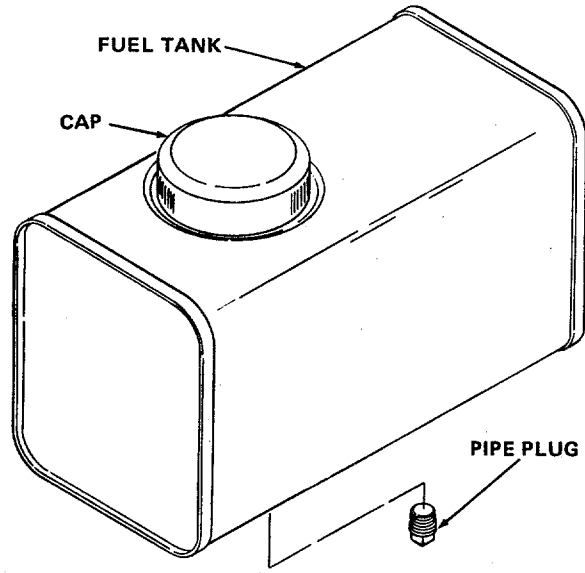

- |    |     |                       |
|----|-----|-----------------------|
| 2. | Cap | Remove fuel tank cap. |
|----|-----|-----------------------|

**FUEL TANK (CONT)**

LOCATION/ITEM	ACTION	REMARKS
---------------	--------	---------

3. Fuel line	<p>Drain contents of fuel line into drain pan. Use 1/2 inch wrench to hold fuel line assembly (1). Use a 9/16 inch wrench to turn swivel fitting on engine fuel pump. Then remove fuel line assembly (1) from fuel filter (2) with a 1/2 inch wrench.</p>	
--------------	---	--

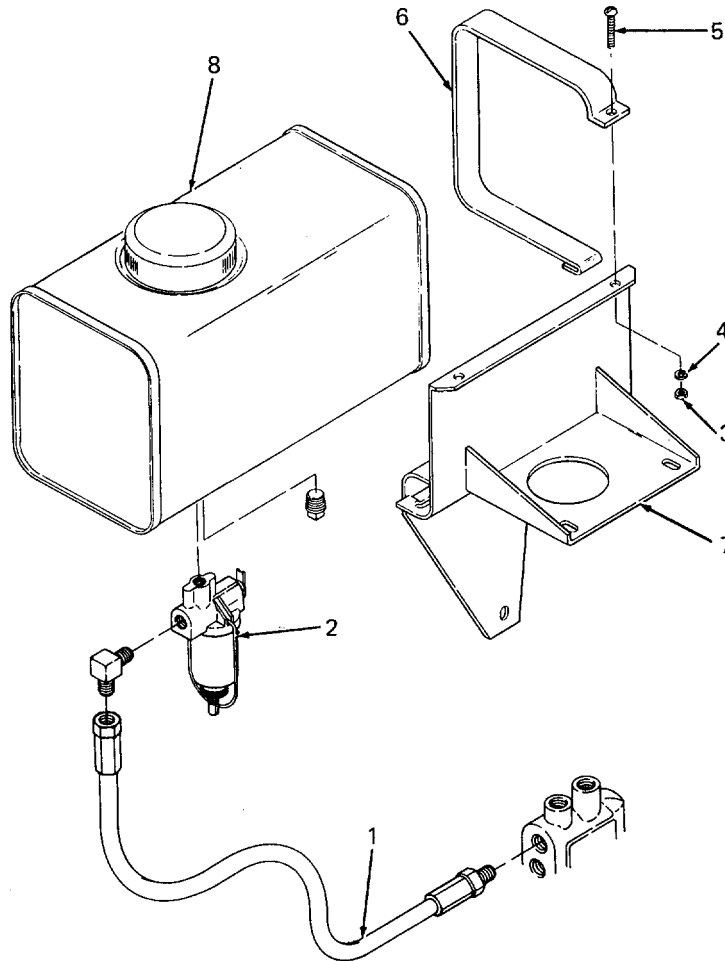

4. Remove screws	<p>Use screwdriver to hold two screws (5). Use 3/8 inch wrench to remove two nuts (3). Remove lockwashers (4).</p>	
------------------	--	--

5. Remove straps	<p>Remove two straps (6) from bracket (7). Remove fuel tank (8).</p>	
------------------	--	--

**FUEL TANK (CONT)**

LOCATION/ITEM	ACTION	REMARKS
---------------	--------	---------

**STRAINER REPLACEMENT**

- |                    |   |  |
|--------------------|---|--|
| 6. Remove strainer | Unscrew cap (1). Remove strainer (3) from tank (4). |  |
|--------------------|---|--|

**NOTE**

**Cap is secured to fuel tank by chain (2).**

- |                     |   |  |
|---------------------|---|--|
| 7. Install strainer | Insert new strainer (3) into tank (4). Install cap (1). |  |
|---------------------|---|--|

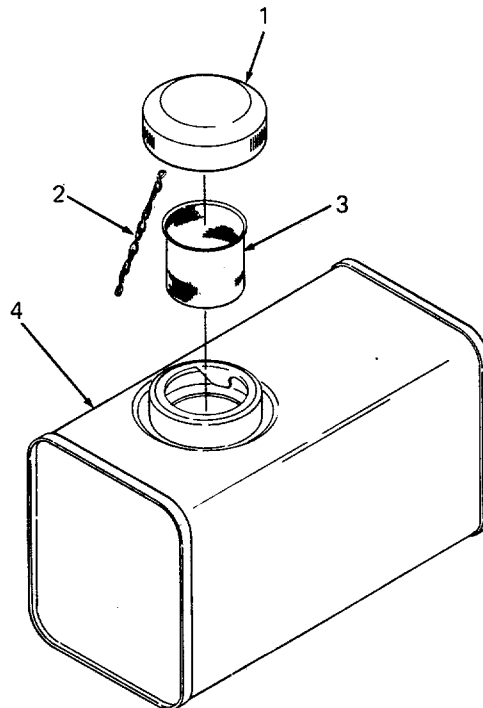

FUEL TANK (CONT)

LOCATION/ITEM	ACTION	REMARKS
---------------	--------	---------

INSTALLATION

8. Install straps

Slide straps (6) over each end of the fuel tank (8). Install straps (6) with fuel tank (8) on bracket (7)

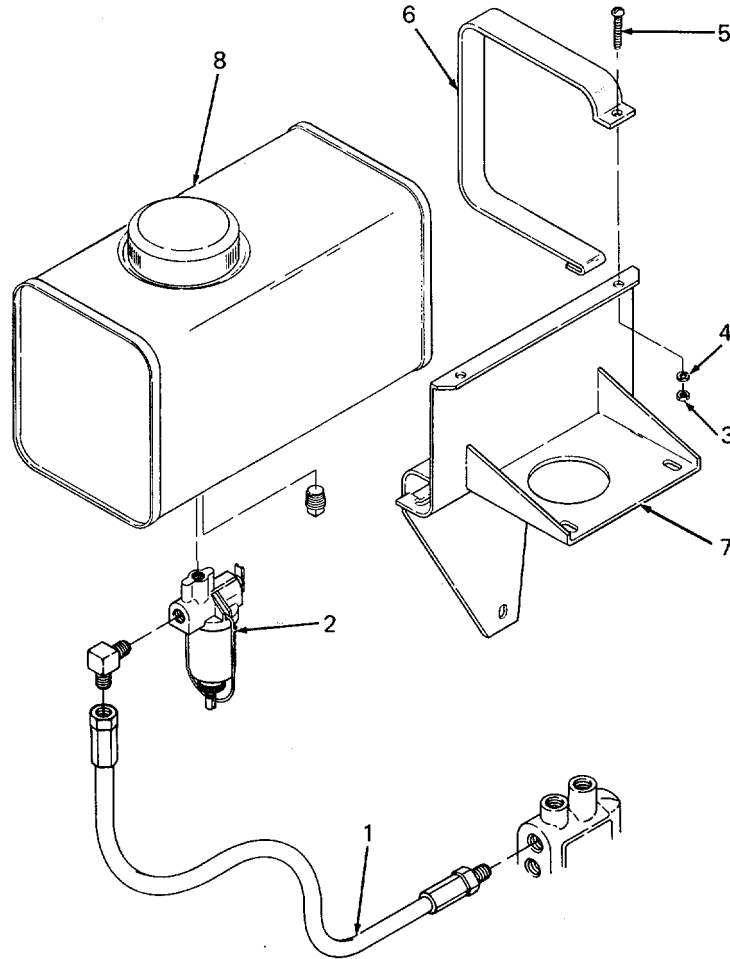

9. Install screws

Insert screws (5) through ends of straps (6). Install lockwashers (4) and nuts (3). Use Loctite on threads.

10. Tighten screws

Use 3/8 inch wrench to hold nuts (3). Use screwdriver to tighten each screw (5).



**FUEL TANK (CONT)**

LOCATION/ITEM	ACTION	REMARKS
---------------	--------	---------

11. Fuel line	Use 1/2 inch wrench to attach fuel line assembly (1) to fuel filter (2). Then attach fuel line assembly to engine fuel pump. Use a 1/2 inch wrench to hole fuel line assembly and a 9/16 inch wrench to turn swivel fitting on engine fuel pump.	
---------------	--	--

12. Cap	Install fuel tank cap.	
---------	------------------------	--

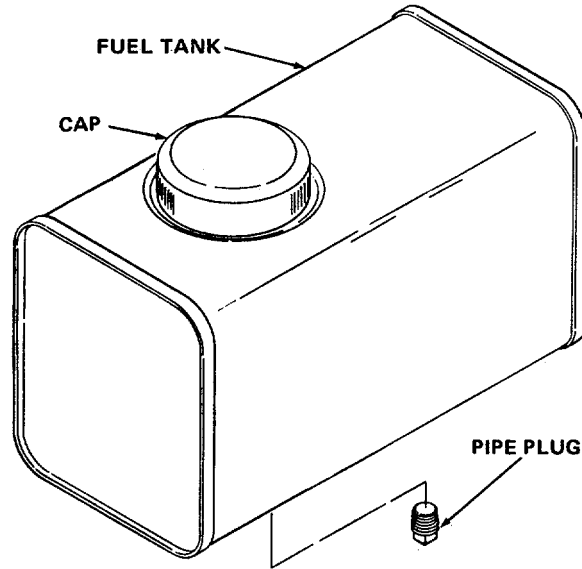

13. Pipe plug	Use 7/16 inch wrench to install pipe plug. Use Loctite on threads.	
---------------	--	--

---

**4-15. FUEL LINE**

---

This task covers:

- a. Removal
  - b. Installation
- 

**INITIAL SETUP****Test Equipment**

None

**Equipment Condition**

Fuel filter shutoff valve turned to OFF, shutoff switch off.

**Tools**

Tool kit, general mechanics automotive,  
NSN 5180-00-177-7033  
Wrench 1/2 inch  
Wrench, 9/16 inch  
Drain pan

**Special Environmental Conditions**

Well-ventilated area required when gasoline is handled.

**Materials/Parts**

Fuel line assembly (Appendix C, item 12, fig.2)

**General Safety Instructions****WARNING**

- Allow engine to cool before performing any maintenance.
- Perform maintenance outdoors or in a well-ventilated area to avoid illness caused by inhalation of fuel fumes.

**References**

None

**Troubleshooting References**

None

---

---

**FUEL TANK (CONT)**

---

LOCATION/ITEM	ACTION	REMARKS
---------------	--------	---------

**REMOVAL****WARNING**

Severe burns, illness, or death can result from improper handling of gasoline. When working with gasoline:

- Do not inhale vapors.
- Work in well-ventilated area.
- Do not work near open flame, sparks, or excessive heat.

- |                |   |
|----------------|---|
| 1. Drain line  | Drain contents of fuel line into drain pan. Use 1/2 inch and 9/16 inch wrenches to remove fuel line from fitting on engine fuel pump. |
| 2. Remove line | Use 1/2 inch wrench to remove fuel line from fuel filter.   |

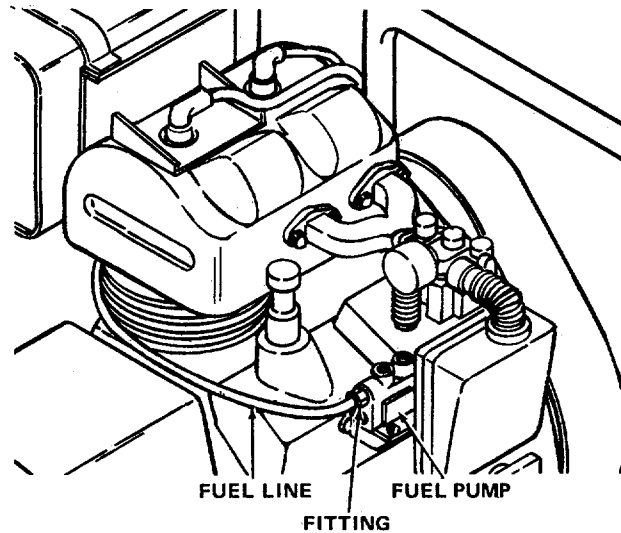
**INSTALLATION**

- |                          |  |
|--------------------------|--|
| 3. Install line          | Use 1/2 inch wrench to install fuel line to fuel filter.                                 |
| 4. Attach line to engine | Use 1/2 inch and 9/16 inch wrenches to install fuel line to fitting on engine fuel pump. |

**4-16. FRAME ASSEMBLY**

**This task covers:**

- a. **Disassembly**
- b. **Inspection**
- c. **Cleaning.**
- d. **Assembly**

**INITIAL SETUP**

**Test Equipment**

None

U-Bolt (Appendix C, item 16, fig.3)

Axle (Appendix C, item 17, fig. 3)

Engine mount (Appendix C, item 7, fig.3)

**Tools**

Tool kit, general mechanics automotive,  
NSN 5180-00-177-7033

Loctite (Item 7, Appendix D)

Cleaning solvent, P-D-680

- Screwdriver, Phillips, cross
- Pliers, long, round nose
- Wrench, 1/2 inch, or
- Socket, 1/2 inch, and handle
- Wrench, 9/16 inch, or
- Socket, 9/16 inch, and handle

**References**

None

**Troubleshooting References**

None

Shop equipment, automotive  
maintenance and repair,  
NSN 4910-00-754-0654

**Equipment Condition**

Gear reducer, pump, and wheel assemblies  
removed for access to frame assembly.

Torque wrench, 0-175 ft lb (0-250 N•m)

**Special Environmental Conditions**

Well-ventilated area required when  
solvent is used.

**Materials/Parts**

- Draw bar (Appendix C, item 1, fig.3)
- Engine guard (Appendix C, item 3, fig.3)
- Frame assembly (Appendix C, item 18, fig.3)

**General Safety Instructions**

None

**FRAME ASSEMBLY (CONT)**

LOCATION/ITEM	ACTION	REMARKS
---------------	--------	---------

**DISASSEMBLY**

- |               |   |  |
|---------------|---|--|
| 1. Draw bar   | Pull hitch pins (3) from each side of draw bar (4). Pull draw bar in and away from frame. |  |
| 2. Hitch pins | Use cross point screwdriver to remove screw (1).  |  |

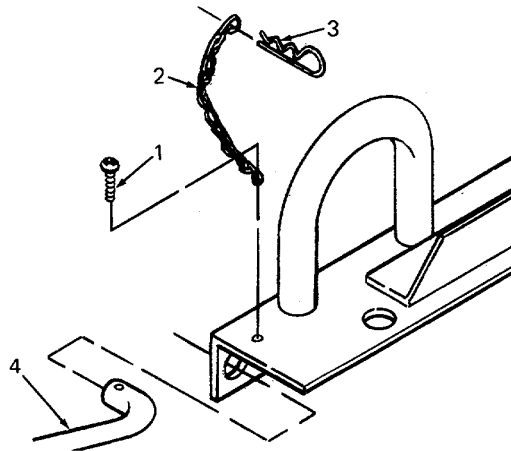

- |          |  |  |
|----------|--|--|
| 3. Chain | Use pliers to separate the chain (2) and hitch pin (3).  |  |
| 4. Axle  | Use 1/2 inch wrench to remove nuts (1) from U-bolts (3). Remove lockwashers (2). Axle (4) can be removed by loosening nuts (1) on U-bolts (3). |  |

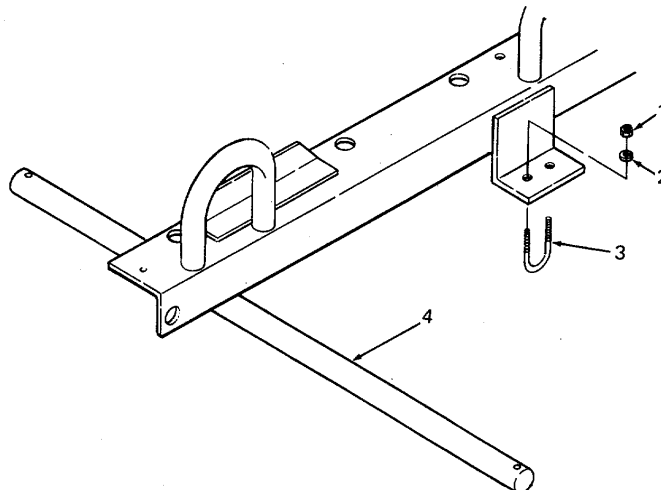

**FRAME ASSEMBLY (CONT)**

LOCATION/ITEM	ACTION	REMARKS
---------------	--------	---------

- |                 |   |  |
|-----------------|---|--|
| 5. Engine guard | Use a 9/16 inch wrench to remove 4 cap screws (1). Pull engine guard (2) away from frame. |  |
|-----------------|---|--|

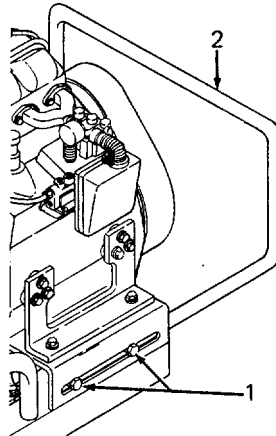

- |                 |   |  |
|-----------------|---|--|
| 6. Engine mount | Use a 9/16 inch wrench to hold cap screws (1) while removing nuts (2) with a 9/16 inch socket and handle. Remove cap screw (1), nut (2), lock-washer (3), and engine mount (4). |  |
|-----------------|---|--|

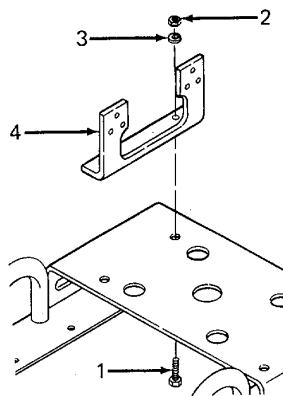

**INSPECTION**

- |  |   |  |
|--|---|--|
| 7. Frame                                     | Inspect frame for warpage. Notify direct support maintenance if warpage affects performance. Inspect frame for cracks or other damage. Notify direct support maintenance if damage or cracks are evident. |  |
| 8. Draw bar, engine guard, and engine mounts | Inspect for cracks and warpage. Replace if damaged.   |  |

**FRAME ASSEMBLY (CONT)**

LOCATION/ITEM	ACTION	REMARKS
9. Hitch pins	Inspect hitch pins for cracks and spring tension. If pins are cracked or if they have no spring tension, replace them.	
10. Chains	Inspect for cracked; or damaged links. Replace the chain if cracked or if damage affects the connecting of the chain to the hitch pin or screw.	
11. Axle	Inspect for distortion or damage to the cotter pin holes. Notify direct support maintenance if distortion or damage is evident.	
12. U-bolts	Inspect for thread damage. Replace damaged U-bolts.	

**CLEANING**

**WARNING**

**Clean parts in a well-ventilated area. Avoid inhalation of solvent fumes and prolonged exposure of skin to cleaning solvent. Wash exposed skin thoroughly. Dry cleaning solvent (fed spec P-D-680) used to clean parts is potentially dangerous to personnel and property. Do not use near open flame or excessive heat. Flash point of solvent is 100° F (38° C).**

13. Hitch pins, chains, and U-bolts	Immerse hitch pins and chains in cleaning solvent, P-D-680. After cleaning, wipe dry.	
14. Frame, axle, draw bar, engine guard, and engine mounts	Clean frame and axle with dry cleaning solvent, P-D-680. Use a stiff-bristle brush to remove caked dirt.	

**FRAME ASSEMBLY (CONT)**

LOCATION/ITEM	ACTION	REMARKS
---------------	--------	---------

**ASSEMBLY**

15. Axle  
Set axle (4) against frame and hold in place with U-bolts (3). Install lockwashers (2) and nuts (1). Use Loctite on threads.

16. Align axle  
Slide axle (4) in U-bolts (3) until each end of the axle is equal distance from the frame.

17. Nuts  
Use 1/2 inch wrench to tighten nuts (1) to 4 ft lb (5 N•m).

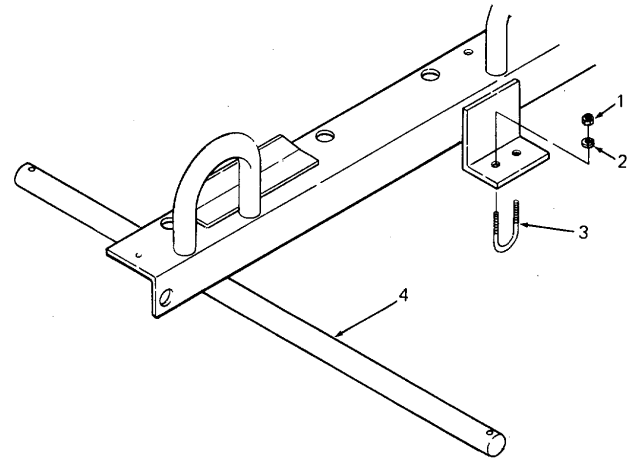

**NOTE**  
Do not tighten U-bolts against axle.

18. Chains  
Install hitch pin (3) on chain (2).

19. Screws  
Insert screw (1) through the last link in chain (2). Use cross point screwdriver to install screw (1) into frame. Use Loctite on threads.

20. Draw bar  
Insert draw bar (4) ends into frame. Install hitch pins (3) into each end of draw bar.

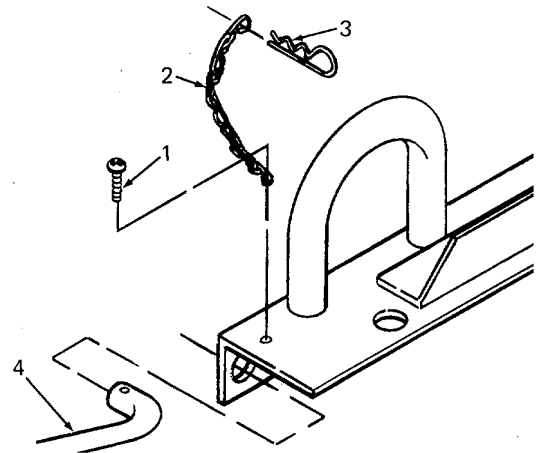



**FRAME ASSEMBLY (CONT)**

LOCATION/ITEM	ACTION	REMARKS
---------------	--------	---------

21. Engine guard

Install cap screws (1) and use a 9/16 inch socket with a torque wrench to tighten cap screws (1) to 30 ft lb (40 N.m). Coat threads with Loctite and install cap screws (1).

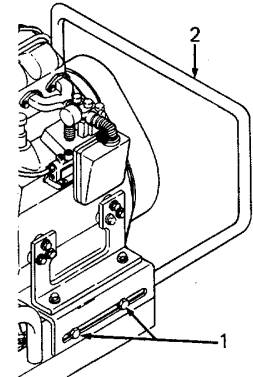

22. Engine mount

Use a 9/16 inch wrench to hold cap screws (1). Install lockwashers (3) and nuts (2). Use a 9/16 inch socket with a torque wrench to tighten nuts (2) to 30 ft lb (40 N.m).

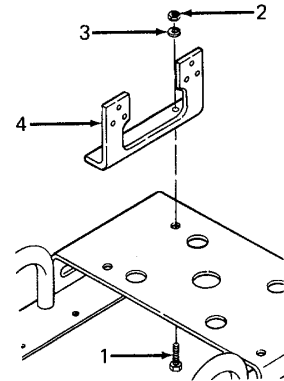

**NOTE**

**When engine mounts (4) are replaced, the engine must be aligned with the coupling halves. The proper alignment is when both coupling halves slide together freely.**

**4-17. WHEEL ASSEMBLY**

**This task covers:**

- |                    |                       |                        |
|--------------------|-----------------------|------------------------|
| <b>a. Removal</b>  | <b>b. Disassembly</b> | <b>c. Inspection</b>   |
| <b>c. Cleaning</b> | <b>e. Assembly</b>    | <b>g. Installation</b> |

**INITIAL SETUP**

**Test Equipment**

None

**References**

None

**Tools**

Tool kit, general mechanics automotive,  
NSN 5180-00-177-7033  
Tire iron  
Pliers, long, round nose

**Troubleshooting References**

None

**Special Environmental Conditions**

Well-ventilated area required when  
solvent is used.

**Materials/Parts**

Cotter pin (Appendix C, item 8, fig.3)  
Wheel assembly (Appendix C, item 10, fig.3)  
Cleaning solvent, P-D-680

**General Safety Instructions**

None

**WHEEL ASSEMBLY (CONT)**

LOCATION/ITEM	ACTION	REMARKS
---------------	--------	---------

**REMOVAL**

- |               |  |  |
|---------------|--|--|
| 1. Cotter pin | Use pliers to remove cotter pin. Discard cotter pin. |  |
|---------------|--|--|

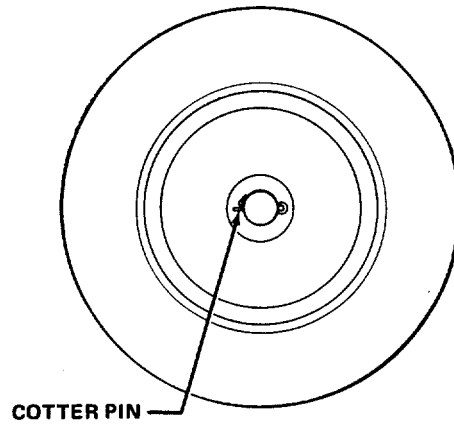

- |                   |   |  |
|-------------------|---|--|
| 2. Wheel assembly | Remove flat washer to remove each wheel assembly. |  |
|-------------------|---|--|

**DISASSEMBLY**

- |                  |  |  |
|------------------|--|--|
| 3. Tire and tube | Use tire iron or other tool to pry the sealing surface of the deflated tire out over the hub assembly (2). Remove tire and tube (1). |  |
|------------------|--|--|

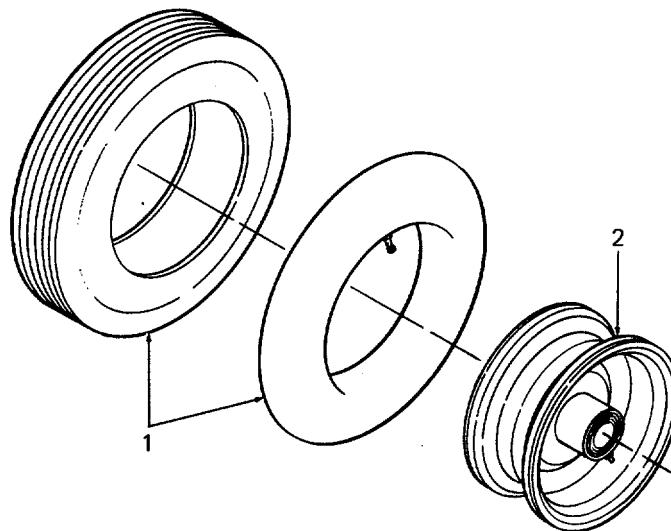

**WHEEL ASSEMBLY (CONT)**

LOCATION/ITEM	ACTION	REMARKS
<b>INSPECTION</b>		
4. Tire	Inspect tires for cuts, punctures, worn threads, imbedded stones, and severe abrasions. Inspect inside of tires for broken cords and punctured walls. Replace tires which are damaged beyond repair or excessively worn.	
5. Tube	Check inner tube for leaks by inflating and immersing it in water. Any sign of bubbles indicates a leak. Patch leaks. Check the tube for dry rot and other signs of deterioration. Replace non-serviceable tubes.	
6. Hub assembly	Inspect the hub assembly for cracks, distortion, burrs on the sealing rim, and other damage. Remove all burrs with file or fine stone. Replace damaged hub assemblies. Inspect bearings for rough, scored, or brinelled rollers, scored races, and bent cages. Replace hub assembly if bearing is damaged.	

**CLEANING**

**WARNING**

**Clean parts in a well-ventilated area. Avoid inhalation of solvent fumes and prolonged exposure of skin to cleaning solvent. Wash exposed skin thoroughly. Dry cleaning solvent (fed spec P-D-680) used to clean parts is potentially dangerous to personnel and property. Do not use near open flame or excessive heat. Flash point of solvent is 100° F (38° C).**

7. Hub assemblies	Clean hub assemblies with cleaning solvent, P-D-680, and dry thoroughly.	
-------------------	--	--

**WHEEL ASSEMBLY (CONT)**

LOCATION/ITEM	ACTION	REMARKS
---------------	--------	---------

**ASSEMBLY**

- |                  |  |  |
|------------------|--|--|
| 8. Tire and tube | Install tire on hub assembly and install inner tube. Be certain valve stem extends in the right direction and through hole in hub (5). Use tire iron to pry outer surface of tire over the hub rim. Inflate to 30 psi (207 kPa). |  |
|------------------|--|--|

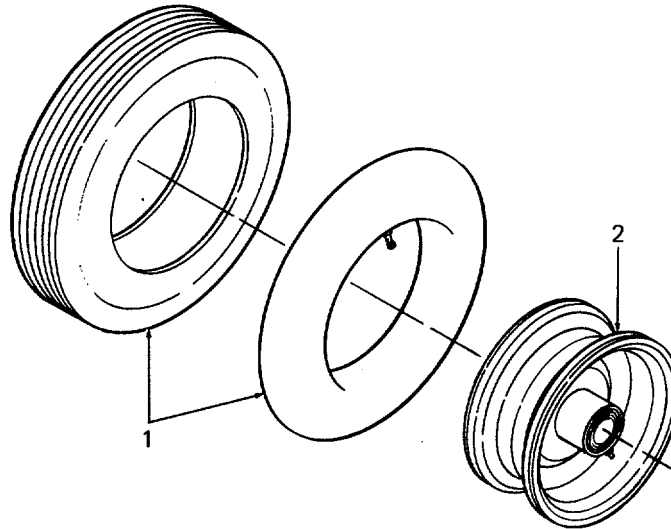

**INSTALLATION**

- |                   |   |  |
|-------------------|---|--|
| 9. Wheel assembly | Install wheel assembly and flat washer on axle. |  |
|-------------------|---|--|

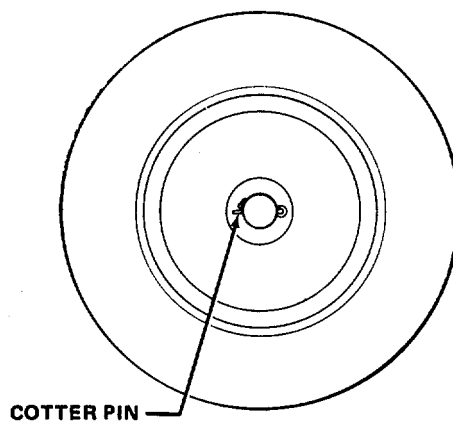

- |                     |   |  |
|---------------------|---|--|
| 10. Cotter pin      | Insert a new cotter pin through hole in axle. Use pliers to bend one leg of the cotter pin along the contour of the axle. |  |
| 11. Grease fittings | Lubricate wheels in accordance with lubrication order LO 5-4320-275-12.   |  |

**4-18. DATA PLATES**

**This task covers:**

- |                |             |            |
|----------------|-------------|------------|
| a. Inspection  | b. Cleaning | c. Removal |
| d. Replacement |             |            |

**INITIAL SETUP**

LOCATION/ITEM	ACTION	REMARKS
<b>Test Equipment</b> None		<b>References</b> None
<b>Tools</b> Shop equipment, automotive maintenance and repair, NSN 4910-00-754-0654 Rivet kit Hammer, hand Alpha-numeric die set Drill, electric Drill, twist, 1/8 inch		<b>Troubleshooting References</b> None  <b>Special Environmental Conditions</b> Well-ventilated area required when solvent is used.  <b>General Safety Instructions</b>
<b>Materials/Parts</b> Rivet (Appendix C, item 1, fig.4) Serial plate (Appendix C, item 3, fig.4) Operating plate (Appendix C, item 4, fig.4) Cleaning solvent, P-D-680		None

---

**DATA PLATES (CONT)**

---

LOCATION/ITEM	ACTION	REMARKS
---------------	--------	---------

**INSPECTION**

- |                |   |  |
|----------------|---|--|
| 1. Data plates | Inspect for legibility. If illegible, replace data plate. |  |
|----------------|---|--|

**CLEANING**

**WARNING**

**Clean parts in a well-ventilated area. Avoid inhalation of solvent fumes and prolonged exposure of skin to cleaning solvent. Wash exposed skin thoroughly. Dry cleaning solvent (fed spec P-D-680) used to clean parts is potentially dangerous to personnel and property. Do not use near open flame or excessive heat. Flash point of solvent is 100° F (38°C).**

- |                |  |  |
|----------------|--|--|
| 2. Data plates | Wipe data plates with a soft cloth moistened with dry cleaning solvent, P-D-680. Wipe dry. |  |
|----------------|--|--|

**REMOVAL**

- |                |  |  |
|----------------|--|--|
| 3. Date plates | Use an electric drill with a 1/8 inch twist drill to remove rivets holding data plate. |  |
|----------------|--|--|

**REPLACEMENT**

- |                         |   |  |
|-------------------------|---|--|
| 4. Identification plate | Use blank serial plate for replacement of the identification plate. Use hammer and die set to stamp serial plate with information applicable to each identification plate for each pump assembly. |  |
|-------------------------|---|--|

**NOTE**

**Where information on the identification plate is illegible, leave the block blank on the serial plate.**

- |                |   |  |
|----------------|---|--|
| 5. Data plates | Use a rivet kit to install data plates on coupling guard. |  |
|----------------|---|--|

**4-19. ACCUMULATOR**

**This task covers:**

- |   |  |  |
|---|--|--|
| <ul style="list-style-type: none"> <li>a. Removal</li> <li>d. Assembly</li> </ul> | <ul style="list-style-type: none"> <li>b. Inspection</li> <li>e. Installation</li> </ul> | <ul style="list-style-type: none"> <li>c. Cleaning.</li> </ul> |
|---|--|--|

**INITIAL SETUP**

**Test Equipment**

None

**Personnel Required: 2**

Mechanic will assist in lifting accumulator.

**Tools**

Shop equipment, automotive maintenance and repair,  
 NSN 4910-00-754-0654  
 Socket, 3/4 inch, and handle  
 Wrench, 1-1/4 inch  
 Wrench, pipe, adj jaw style, 4 inch ips  
 Torque wrench, 0-175 ft lb (0-250 N•m)

**References**

None

**Troubleshooting References**

Malfunction 3, step 2  
 Malfunction 4, step 1  
 Malfunction 4 step 2

**Materials/Parts**

Pipe plug (Appendix C, item 1, fig.6)  
 Accumulator (Appendix C, item 5, fig.6)  
 Gasket (Appendix C, item 6, fig.6)  
 Nipple (Appendix C, item 2, fig.6)  
 Seal plate (Appendix C, item 7, fig.6)  
 Check valve assembly (Appendix C, item 8, fig.6)  
 Cleaning solvent, P-D-680  
 Loctite (Item 7, Appendix D)

**Special Environmental Conditions**

Well-ventilated area required when solvent is used.

**General Safety Instructions**

None



**ACCUMULATOR (CONT)**

LOCATION/ITEM	ACTION	REMARKS
---------------	--------	---------

**REMOVAL**

- |               |   |  |
|---------------|---|--|
| 1. Pipe plug  | Use 1-1/4 inch wrench to remove pipe plug (1) from accumulator.   |  |
| 2. Nipple     | Use pipe wrench to remove nipple (2).   |  |
| 3. Cap screws | Use 3/4 inch socket and handle to remove four cap screws (3) holding accumulator (8) on pump bowl. Remove cap screws (3) and lockwashers (4). |  |

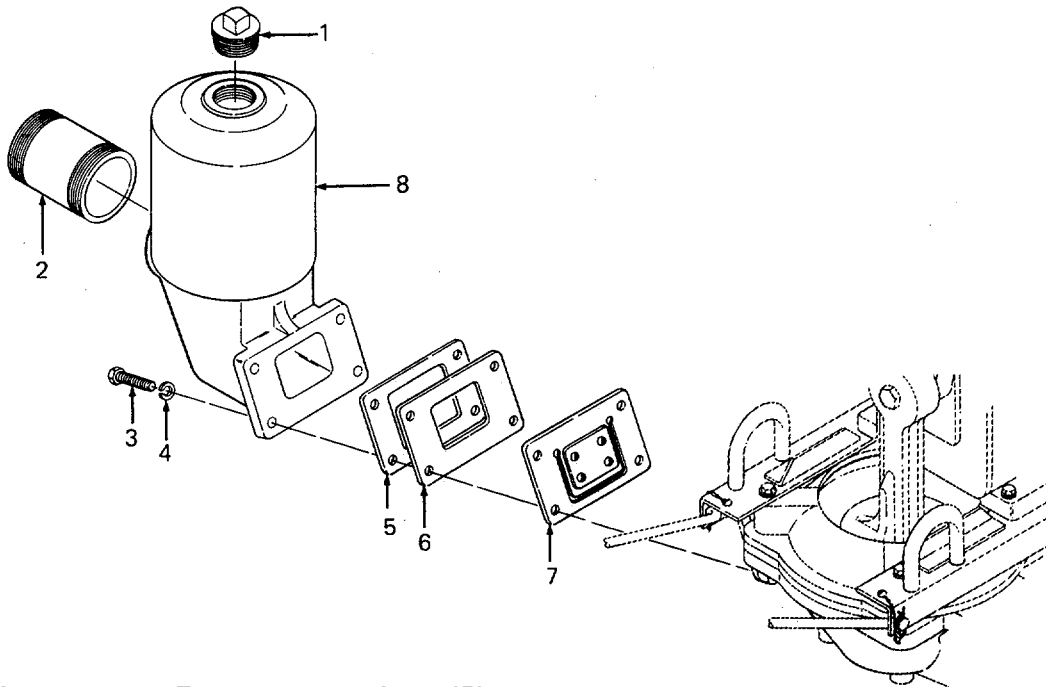

- |                |                         |  |
|----------------|-------------------------|--|
| 4. Accumulator | Remove accumulator (8). |  |
|----------------|-------------------------|--|

**NOTE**

**Gasket (5), seal plate (6), and check valve assembly (7) may stick to accumulator.**

Remove and discard gasket (5). Remove seal plate (6), and check valve assembly (7) from accumulator.

**ACCUMULATOR (CONT)**

LOCATION/ITEM	ACTION	REMARKS
<b>INSPECTION</b>		
5. Accumulator	Inspect accumulator for thread damage and warpage. Replace if damaged or warped.	
6. Pipe plug	Inspect for damaged threads. Replace if damaged.	
7. Nipple	Inspect for damaged threads and cracks. Replace if damaged or cracked.	
8. Seal plate and check valve assembly	Inspect for cracks and warpage. Replace if damaged or warped.	

**CLEANING****WARNING**

**Clean parts in a well-ventilated area. Avoid inhalation of solvent fumes and prolonged exposure of skin to cleaning solvent. Wash exposed skin thoroughly. Dry cleaning solvent (fed spec P-D-680) used to clean parts is potentially dangerous to personnel and property. Do not use near open flame or excessive heat. Flash point of solvent is 100° F (38°C).**

9. Accumulator, nipple, seal plate, and check valve assembly	Clean accumulator with cleaning solvent, P-D-680. Use a stiff-bristle brush to remove caked dirt.	
10. Pipe plug	Clean pipe plug with cleaning solvent, P-D-680.	

**INSTALLATION**

11. Accumulator	Place four cap screws (3) with lockwashers (4) through screw holes in accumulator (8). Install gasket (5) and seal plate (6) on cap screws (3). Install check valve assembly (7) on cap screws (3). Use Loctite on screw threads.	
-----------------	---	--

**ACCUMULATOR (CONT)**

12. Cap screws

Align cap screws with accumulator, gasket, and check valve assembly to threaded screw holes in pump bowl. Use 3/4 inch socket with a torque wrench to tighten the four cap screws to a torque of 40 ft lb (54 N•m).

13. Nipple

Use Loctite on nipple threads. Use pipe wrench to install nipple (2).

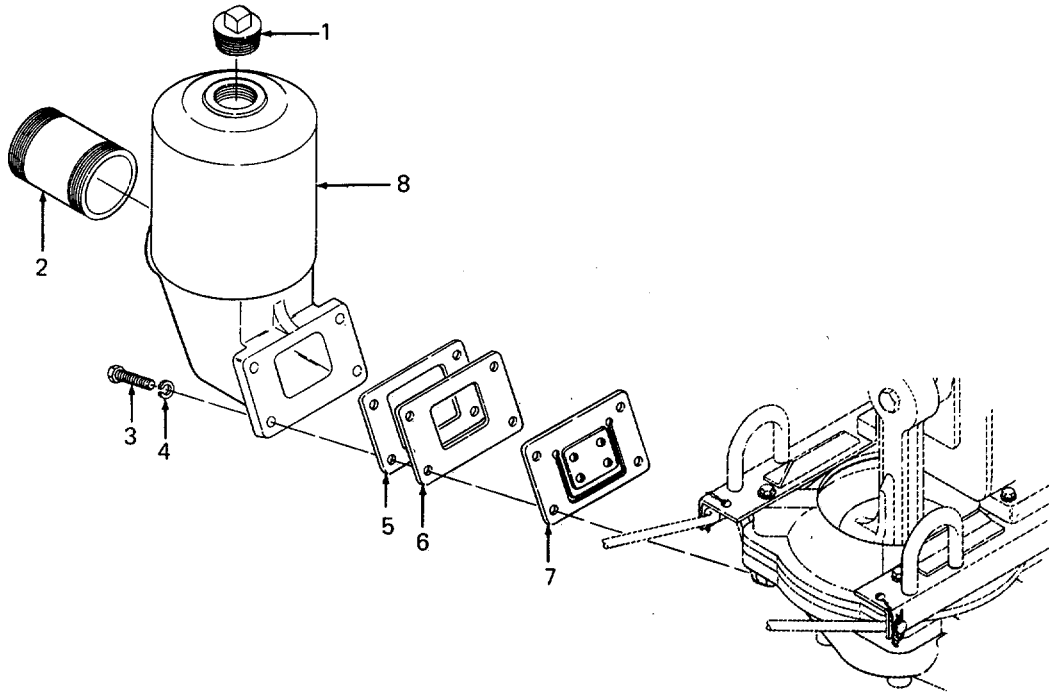

14. Pipe plug

Use Loctite on pipe plug threads. Use 1-1/4 inch wrench to install pipe plug (1).

**4-20. DISCHARGE PORT**

This task covers:

- a. Removal
- b. Inspection
- c. Cleaning.
- d. Installation

**INITIAL SETUP**

**Test Equipment**

None

**Tools**

Shop equipment, automotive maintenance and repair, NSN 4910-00-754-0654

- Socket, 3/4 inch, and handle
- Wrench, pipe, adj jaw style, 4 inch ips
- Torque wrench 0-175 ft lb (0-250 N•m)

**Materials/Parts**

- Nipple (Appendix C, item 2, fig.6)
- Gasket (Appendix C, item 6, fig.6)
- Seal plate (Appendix C, item 7, fig.6)

- Check valve assembly (Appendix C, item 8, fig.6)
- Discharge port (Appendix C, item 9, fig.6)
- Cleaning solvent, P-D-680
- Loctite (Item 7, Appendix D)

**References**

None

**Troubleshooting References**

None

**Special Environmental Conditions**

Well-ventilated area required when solvent is used.

**General Safety Instructions**

None

---

**DISCHARGE PORT (CONT)**

---

**REMOVAL**

1. Nipple                                      Use pipe wrench to remove nipple (1) from discharge port (4).
2. Screws                                    Use 3/4 inch socket and handle to remove four cap screws (2) holding discharge port (4) on pump bowl. Remove cap screws (2) and lock-washers (3).

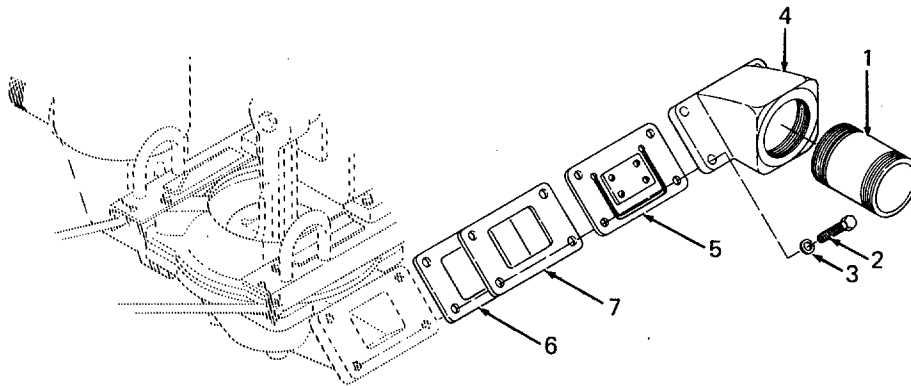

3. Discharge port                            Remove discharge port (4).

**NOTE**

**Gasket (6), seal plate (7), and check valve assembly (5) may stick to the discharge port.**

Remove and discard gasket (6). Remove seal plate (7), and check valve assembly (5) from discharge port.

**INSPECTION**

4. Discharge port                            Inspect discharge port for thread damage and warpage. Replace if damaged or warped.
5. Seal plate and check valve assembly      Inspect for cracks or warpage. Replace if damaged.
6. Nipple                                      Inspect for damaged threads and cracks. Replace if damaged or cracked.

**DISCHARGE PORT (CONT)**

LOCATION/ITEM	ACTION	REMARKS
---------------	--------	---------

**CLEANING**

**WARNING**

Clean parts in a well-ventilated area. Avoid inhalation of solvent fumes and prolonged exposure of skin to cleaning solvent. Wash exposed skin thoroughly. Dry cleaning solvent (fed spec P-D-680) used to clean parts is potentially dangerous to personnel and property. Do not use near open flame or excessive heat. Flash point of solvent is 100°F (38°C).

- |   |   |  |
|---|---|--|
| 7. Discharge port, nipple, seal plate, and check valve assembly | Clean with cleaning solvent, P-D-680. Use a stiff-bristle brush to remove caked dirt. |  |
|---|---|--|

**INSTALLATION**

- |                   |  |  |
|-------------------|--|--|
| 8. Discharge port | Place four cap screws (2) with lockwashers (3) through screw holes in discharge port (4). Install check valve assembly (5), seal plate (7), and gasket (6) on cap screws (2). Use Loctite on screw threads.                      |  |
| 9. Cap screws     | Align cap screws with discharge port, gasket, seal plate, and check valve assembly to threaded screw holes in pump bowl. Use 3/4 inch socket with torque wrench to tighten the four cap screws to a torque of 40 ft lb (54 N•m). |  |
| 10. Nipple        | Use Loctite on nipple threads. Use pipe wrench to install nipple (1).  |  |

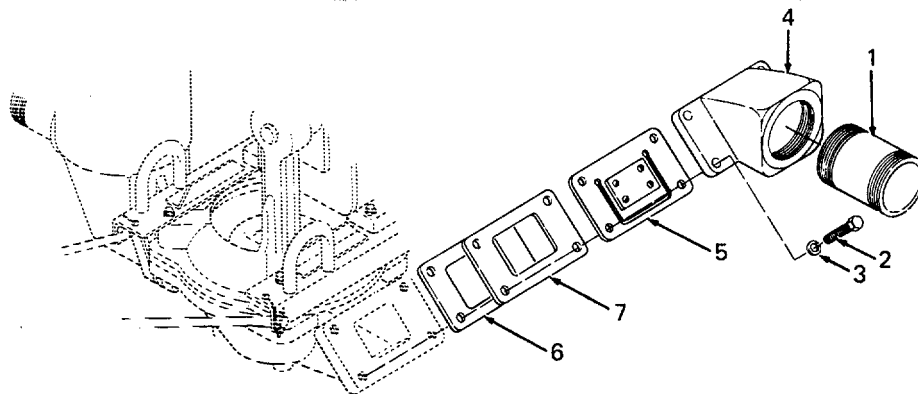

**4-21. DIAPHRAGM**

**This task covers:**

- |                                       |                      |                     |
|---------------------------------------|----------------------|---------------------|
| <p>a. Removal<br/>d. Installation</p> | <p>b. Inspection</p> | <p>c. Cleaning.</p> |
|---------------------------------------|----------------------|---------------------|

**INITIAL SETUP**

**Test Equipment**

None

**Personnel Required: 2**

Mechanic will assist in lifting pump assembly.

**Tools**

Shop equipment, automotive maintenance and repair, NSN 4910-00-754-0654

- Socket, 15/16 inch, and handle
- Socket, 3/4 inch, and handle
- Torque wrench, 0-175 ft lb (0-250 N.m)

**References**

None

**Troubleshooting References**

None

**Equipment Condition**

Drain plug removed from pump bowl to remove fluid from pump

**Materials/Parts**

- Diaphragm (Appendix C, item 6, fig. 7)
- Loctite (Item 7, Appendix D)
- Cleaning solvent, P-D-680

**Special Environmental Conditions**

Well-ventilated area required when solvent is used.

**General Safety Instructions**

None

**DIAPHRAGM (CONT)**

LOCATION/ITEM	ACTION	REMARKS
---------------	--------	---------

**REMOVAL**

1. Pump bowl assembly

Use 15/16 inch socket and handle to remove four cap screws (1) and lockwashers (2) holding pump bowl assembly (3) to diaphragm clamp (8).

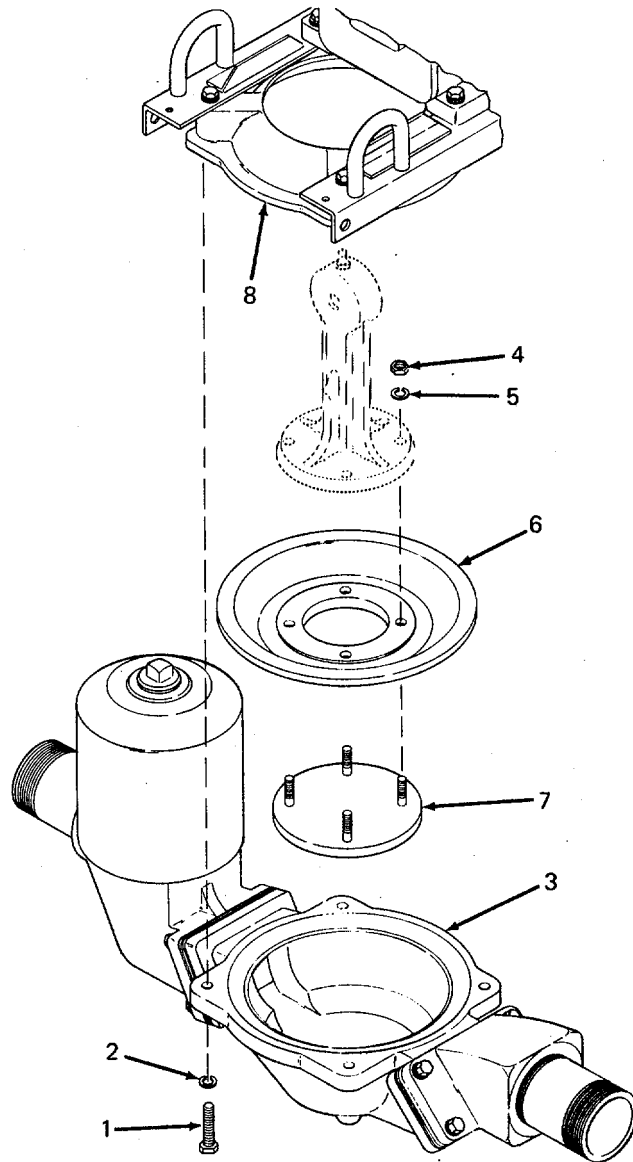



**DIAPHRAGM (CONT)**

LOCATION/ITEM	ACTION	REMARKS
---------------	--------	---------

**NOTE**

Use draw bar to lift pump assembly up and away from pump bowl assembly (3). The pump assembly will pivot on its wheels to aid in lifting.

- |              |  |  |
|--------------|--|--|
| 2. Nuts      | To break seal, pull diaphragm (6) away from lip of diaphragm clamp (8). Use 3/4 inch socket and handle to loosen four nuts (4). Remove nuts (4) and lockwashers (5). |  |
| 3. Diaphragm | Pull clamp assembly (7) away from connecting rod. Separate diaphragm (6) from clamp assembly (7).  |  |

**INSPECTION**

- |              |   |  |
|--------------|---|--|
| 4. Diaphragm | Inspect diaphragm for cracks or tears. Replace damaged diaphragm. |  |
|--------------|---|--|

**CLEANING**

**WARNING**

Clean parts in a well-ventilated area. Avoid inhalation of solvent fumes and prolonged exposure of skin to cleaning solvent. Wash exposed skin thoroughly. Dry cleaning solvent (fed spec P-D-680) used to clean parts is potentially dangerous to personnel and property. Do not use near open flame or excessive heat. Flash point of solvent is 100°F (38°C).

- |              |   |  |
|--------------|---|--|
| 5. Diaphragm | Clean the diaphragm with cleaning solvent, P-D-680. Wipe dry. |  |
|--------------|---|--|

DIAPHRAGM (CONT)

LOCATION/ITEM	ACTION	REMARKS
---------------	--------	---------

INSTALLATION

- |              |   |  |
|--------------|---|--|
| 6. Diaphragm | Install diaphragm (6) over studs on clamp assembly (7). |  |
|--------------|---|--|

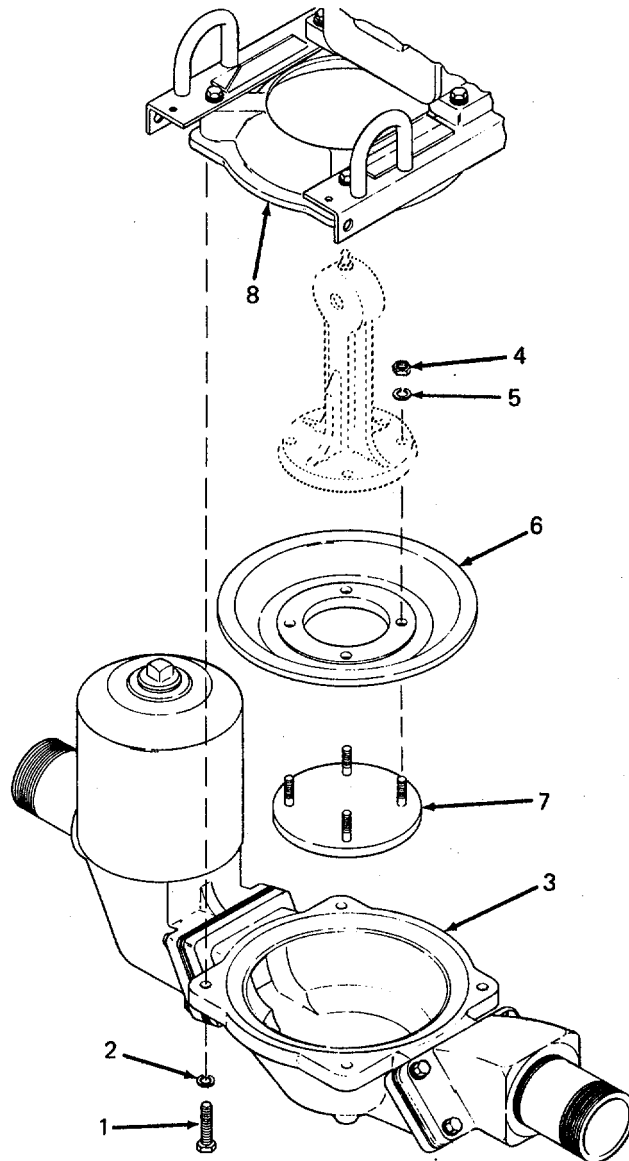

---

**DIAPHRAGM (CONT)**

---

LOCATION/ITEM	ACTION	REMARKS
7. Clamp assembly	Install clamp assembly (7) with diaphragm (6) on connecting rod.	
8. Nuts	Use Loctite on threads of studs. Install lockwashers (5) and nuts (4). Use 3/4 inch socket with a torque wrench to tighten nuts (4) to 40 ft lb (54 N•m).	
9. Pump bowl assembly	Use the draw bar to lift pump assembly over pump bowl assembly (3).	

**NOTE**

The pump assembly will pivot on its wheels to aid in lifting.

**CAUTION**

**Be certain diaphragm is seated on pump bowl assembly seat. Align screw holes of pump bowl assembly (3) with threaded holes in diaphragm clamp (8). Install cap screws (1) and lockwashers (2). Use Loctite on screw threads.**

10. Cap screws	Use 15/16 inch socket with torque wrench to tighten cap screws (1) to 75 ft lb (102 N•m).	
----------------	---	--

---

**4-22. CLAMP ASSEMBLY**

This task covers:

- a. Disassembly
- b. Inspection
- c. Cleaning
- d. Assembly

**INITIAL SETUP**

**Test Equipment**

None

**References**

None

**Tools**

Shop equipment, automotive maintenance and repair, NSN 4910-00-754-0654

Stud removing and installing tool, 1/2 inch

**Troubleshooting References**

None

**Equipment Condition**

Pump bowl assembly and diaphragm removed for access to clamp assembly.

**Materials/Parts**

Stud (Appendix C, item 8, fig. 7)

Connecting rod clamp (Appendix C, item 9, fig. 7)

Loctite (Item 7, Appendix D)  
Cleaning solvent, P-D-680

**Special Environmental Conditions**

Well-ventilated area required when solvent is used.

**General Safety Instructions**

None

**CLAMP ASSEMBLY (CONT)**

LOCATION/ITEM	ACTION	REMARKS
---------------	--------	---------

**DISASSEMBLY**

- |          |  |  |
|----------|--|--|
| 1. Studs | Use 1/2 inch stud removing and installing tool to remove studs (1): from connecting rod clamp (2). |  |
|----------|--|--|

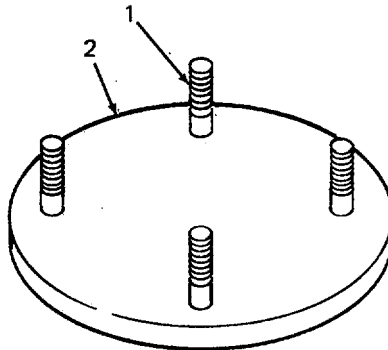

**INSPECTION**

- |                         |  |  |
|-------------------------|--|--|
| 2. Threads              | Inspect threads on studs. (1) and threads in connecting rod clamp (2) for damage. Replace damaged parts. |  |
| 3. Connecting rod clamp | Inspect connecting rod clamp (2) for cracks or warpage. Replace if damaged.                              |  |

**CLEANING**

**WARNING**

**Clean parts in a well-ventilated area. Avoid inhalation of solvent fumes and prolonged exposure. of skin to cleaning solvent. Wash exposed skin thoroughly. Dry cleaning solvent (fed spec P-D,680) used to clean parts is potentially dangerous to personnel and property. Do not use near open flame or excessive heat. Flash point of solvent is 100°F (38°C).**

- |                                   |  |  |
|-----------------------------------|--|--|
| 4. Studs and connecting rod clamp | Clean studs and connecting rod clamp with cleaning solvent, P-D-680. Use a stiff-bristle brush to remove caked dirt. |  |
|-----------------------------------|--|--|

**CLAMP ASSEMBLY (CONT)**

LOCATION/ITEM	ACTION	REMARKS
---------------	--------	---------

**ASSEMBLY**

5. Studs

Use Loctite on stud threads. Use 1/2 inch stud removing and installing tool to install studs (1) into connecting rod clamp (2). Tighten studs until they are flush with bottom of connecting rod clamp.

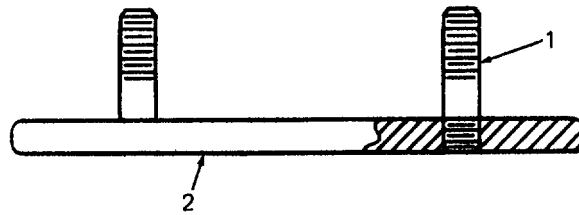

**4-23. PUMP BOWL**

This task covers:

- a. Removal of pump bowl from diaphragm clamp.
- b. Disassembly
- c. Inspection
- d. Cleaning
- e. Assembly
- f. Installation of pump bowl on diaphragm clamp.

**INITIAL SETUP**

**Test Equipment**

None

**Personnel Required: 2**

Mechanic will assist in lifting pump assembly and pump bowl.

**Tools**

Shop equipment, automotive maintenance and repair, NSN 4910-00-754-0654

Socket, 15/16 inch, and handle

Wrench, 5/8 inch

Torque wrench, 0-175 ft lb (0-250 N•m)

**References**

None

**Troubleshooting References**

None

**Equipment Condition**

Accumulator, discharge port, gaskets, seal plates, and valve assemblies removed for access to pump bowl.

**Materials/Parts**

Drain plug (Appendix C, item 3, fig. 7)

Pump bowl (Appendix C, item 10, fig. 7)

Loctite (Item 7, Appendix D)

Cleaning solvent, P-D-680

**Special Environmental Conditions**

Well-ventilated area required when solvent is used.

**General Safety Instructions**

None

**PUMP BOWL (CONT)**

LOCATION/ITEM	ACTION	REMARKS
---------------	--------	---------

**REMOVAL**

- |              |  |  |
|--------------|--|--|
| 1. Pump bowl | Use 15/16 inch socket and handle to remove four cap screws (1) and lockwashers (2) holding pump bowl (3) to diaphragm clamp (5). |  |
|--------------|--|--|

**NOTE**

Use the draw bar to lift pump assembly up and away from pump bowl. The pump assembly will pivot on its wheels to aid in lifting.

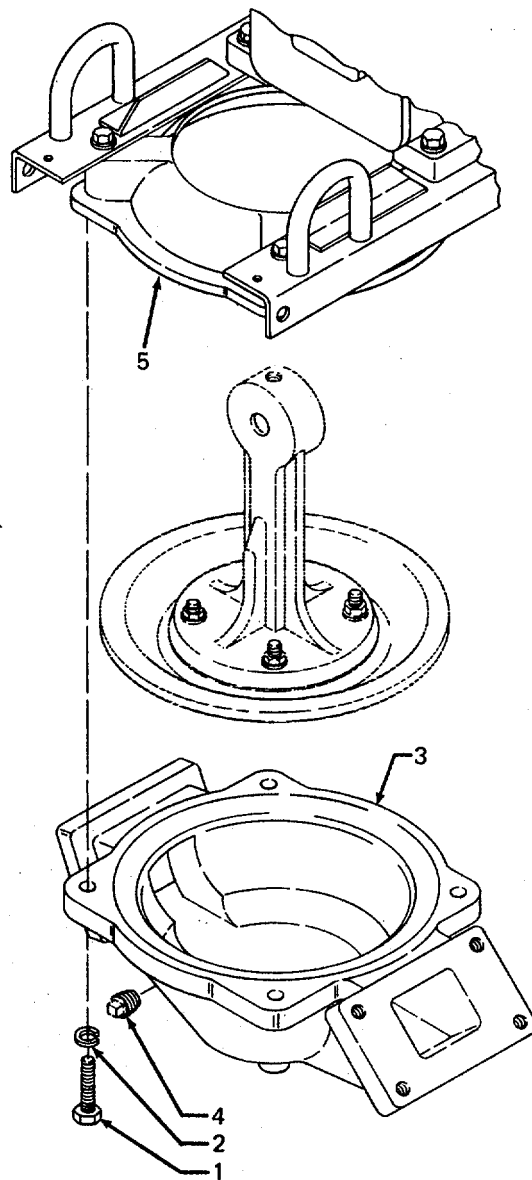



---

**PUMP BOWL (CONT)**

---

LOCATION/ITEM	ACTION	REMARKS
<b>DISASSEMBLY</b>		
2. Drain plug	Use 5/8 inch wrench to remove drain plug (4) from pump bowl (3).	
<b>INSPECTION</b>		
3. Pump bowl	Inspect for cracks, warpage, and damaged threads. Replace pump bowl if damaged.	
4. Drain plug	Inspect for thread damage. Replace drain plug if threads are damaged.	
<b>CLEANING</b>		
<b><u>WARNING</u></b>		
<p><b>Clean parts in a well-ventilated area. Avoid inhalation of solvent fumes and prolonged exposure of skin to cleaning solvent. Wash exposed skin thoroughly. Dry cleaning solvent (fed spec P-D-680) used to clean parts is potentially dangerous to personnel and property. Do not use near open flame or excessive heat. Flash point of solvent is 100°F (38°C).</b></p>		
5. Pump bowl and drain plug	Clean pump bowl and drain plug with cleaning solvent, P-D-680. Use a stiff-bristle brush to remove caked dirt.	

**PUMP BOWL (CONT)**

LOCATION/ITEM	ACTION	REMARKS
---------------	--------	---------

**ASSEMBLY**

- |               |  |  |
|---------------|--|--|
| 6. Drain plug | Use Loctite on drain plug threads. Use 5/8 inch wrench to install drain plug (4) on pump bowl (3). Tighten until plug is snug. |  |
|---------------|--|--|

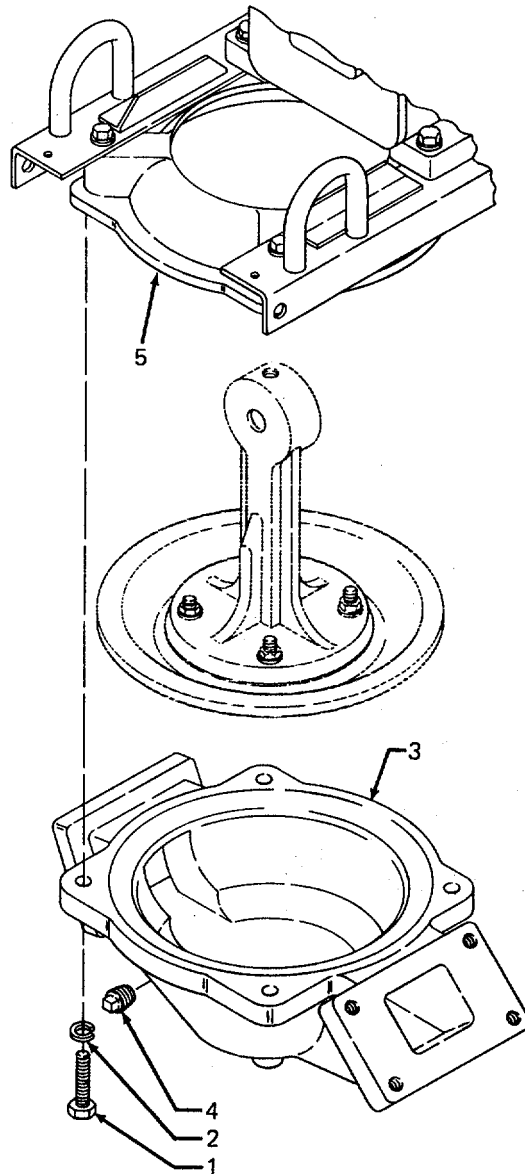

---

**PUMP BOWL (CONT)**

---

LOCATION/ITEM	ACTION	REMARKS
---------------	--------	---------

**INSTALLATION**

- |              |  |  |
|--------------|--|--|
| 7. Pump bowl | Use the draw bar to lift pump assembly over pump bowl (3). |  |
|--------------|--|--|

**NOTE**

**The pump, assembly will pivot on its wheels to aid in lifting.**

Align screw holes of pump bowl (3) with threaded holes in diaphragm clamp (5). Use Loctite on threads. Install cap screws (1) and lockwashers (2).

- |               |   |  |
|---------------|---|--|
| 8. Cap screws | Use 15/16 inch socket with a torque wrench to tighten cap screws (1) to 75 ft lb (102 N•m). |  |
|---------------|---|--|
-

**4-24. CONNECTING ROD ASSEMBLY**

This task covers:

- a. Removal
- b. Disassembly
- c. Inspection
- d. Cleaning
- e. Assembly
- f. Installation

**INITIAL SETUP**

**Test Equipment**

None

**Materials/Parts**

Shoulder bolt (Appendix C, item 3, fig. 8)

Connecting rod assembly (Appendix C, item 4, fig. 8)

**Tools**

Shop equipment, automotive maintenance and repair, NSN 4910-00-754-0654

Crank (Appendix C, item 12, fig. 8)  
Loctite (Item 7, Appendix D)

Cleaning solvent, P-D-680

Wrench, 9/16 inch

**References**

None

Wrench, 1-1/8 inch, or

**Troubleshooting References**

None

Socket, 1-1/8 inch and handle

**Special Environmental Conditions**

Well-ventilated area required when solvent is used.

Socket, 3/4 inch and handle

Wrench, 15/16 inch, or

Socket, 15/16 inch and handle

**General Safety Instructions**

None

Torque wrench, 0-175 ft lb (0-250 N•m)

**CONNECTING ROD ASSEMBLY (CONT)**

LOCATION/ITEM	ACTION	REMARKS
---------------	--------	---------

**REMOVAL**

**NOTE**

**Position connecting rod to the down position.**

- |         |  |
|---------|--|
| 1. Nuts | Use 3/4 inch socket and handle to remove nuts (1). Remove lockwashers (2). |
|---------|--|

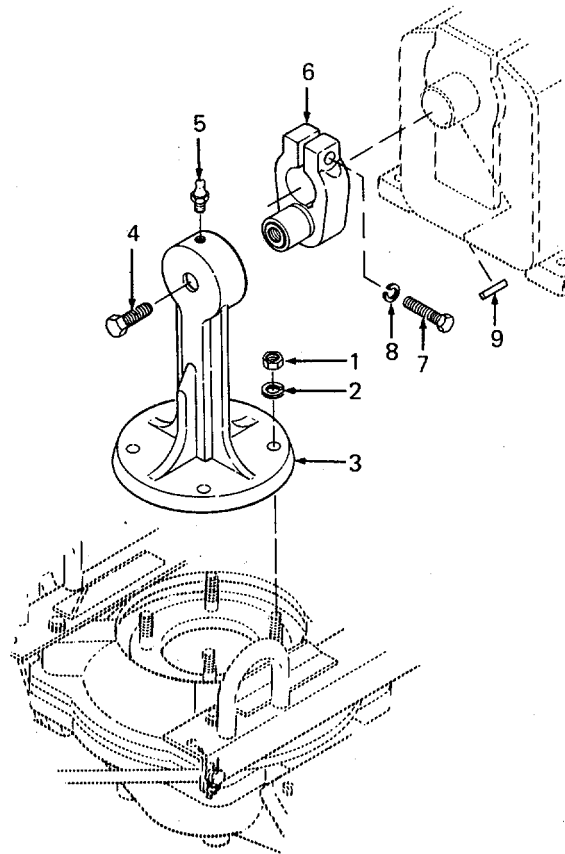

- |                            |   |
|----------------------------|---|
| 2. Connecting rod assembly | Use 1-1/8 inch socket and handle to remove shoulder bolt (4). Hand crank the engine until connecting rod (3) is clear of the studs protruding through the diaphragm. Slide the connecting rod assembly off crank (6). |
|----------------------------|---|

- |          |   |
|----------|---|
| 3. Crank | Use 15/16 inch socket and handle to remove cap screw (7). Remove lockwasher (8). Slide crank (6) off gear reducer shaft. Remove square key (9). |
|----------|---|

---

**CONNECTING ROD ASSEMBLY (CONT)**

---

LOCATION/ITEM	ACTION	REMARKS
<b>DISASSEMBLY</b>		
4. Grease fitting	Use 9/16 inch wrench to remove grease fitting (5).	
<b>INSPECTION</b>		
5. Shoulder bolt	Inspect for damaged threads. Replace if damaged.	
6. Connecting rod	Inspect for cracks, damaged threads in grease fitting hole, galled bearing bore, and warpage. Replace if any damaged is evident.	
7. Crank	Inspect for cracks, damaged threads in grease fitting hole, damaged bearing, and warpage. Replace if any damage is evident.	

**CLEANING****WARNING**

**Clean parts in a well-ventilated area. Avoid inhalation of solvent fumes and prolonged exposure of skin to cleaning solvent. Wash exposed skin thoroughly. Dry cleaning solvent (fed spec P-D-680) used to clean parts is potentially dangerous to personnel and property. Do not use near open flame or excessive heat. Flash point of solvent is 100° F (38° C).**

8. Shoulder bolt and grease fitting	Clean with dry cleaning solvent, P-D-680. Wipe dry.	
9. Connecting rod	Clean with dry cleaning solvent, P-D-680. Use a stiff-bristle brush to remove caked dirt. Use a soft-bristle brush to remove old grease from bearing. Wipe dry. Coat the bearing with light oil.	

**CONNECTING ROD ASSEMBLY (CONT)**

LOCATION/ITEM	ACTION	REMARKS
---------------	--------	---------

10. Crank

Wash in dry cleaning solvent, P-D-680. Use a soft-bristle brush to remove old grease. After cleaning, wipe the bore and journal surfaces with light oil and wrap in lint-free paper until ready to assemble on speed reducer and connecting rod.

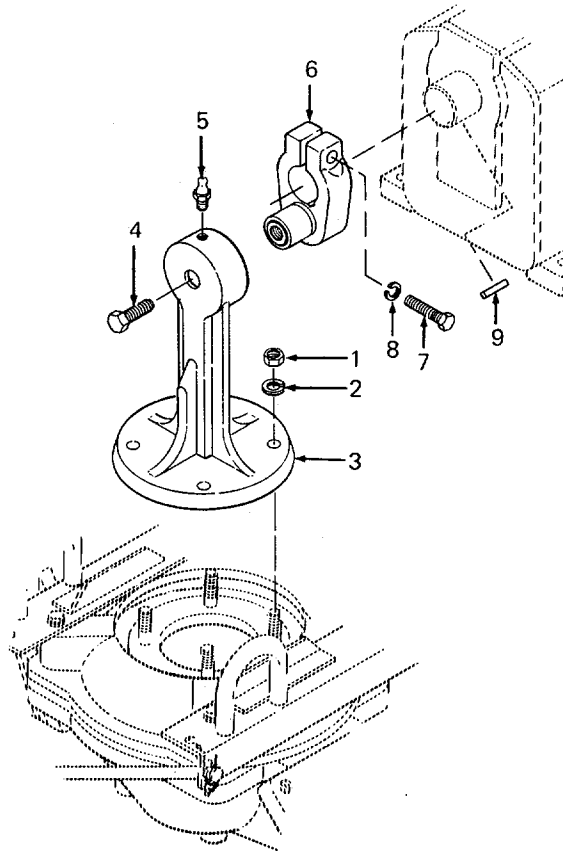

11. Grease fitting

Use 9/16 inch wrench to install grease fitting (5).

**INSTALLATION**

12. Crank

Install square key (9) into keyway in gear reducer shaft. Align keyway of crank (6) with square key (9). Slide crank over square key and onto gear reducer shaft.

**CONNECTING ROD ASSEMBLY (CONT)**

LOCATION/ITEM	ACTION	REMARKS
13. Cap screw and lockwasher	Use Loctite on cap screw threads. Install lockwasher (8) and cap screw (7) on crank. Do not tighten until connecting rod assembly has been installed.	
14. Connecting rod assembly	Hand crank engine until square key is rotated to the 12 o'clock position. Install connecting rod assembly on the crank.	

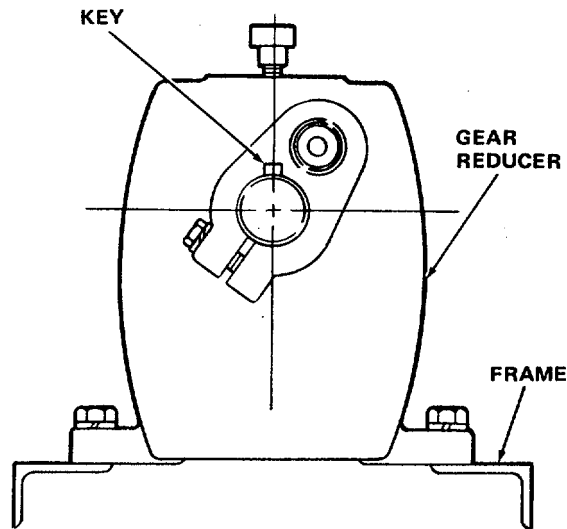

15. Shoulder bolt	Use Loctite on shoulder bolt threads. Install shoulder bolt (4) through connecting rod (3) and into crank (6). Use 1-1/8 inch socket with torque wrench to tighten shoulder bolt (4) to 75 ft lb (102 N•m).	
16. Nuts	Align four holes in connecting rod (3) with studs sticking through diaphragm.	

**NOTE**

**Hand crank the engine to lower the connecting rod to the studs.**

17. Tighten cap screw	Use Loctite on stud threads. Install lockwashers (2) and nuts (1). Use 3/4 inch socket with torque wrench to tighten nuts (1) to 40 ft lb (54 N•m).  Use 15/16 inch socket with torque wrench to tighten cap screw (7) to 75 ft lb (102 N•m).	
-----------------------	---	--



**4-25. COUPLING**

This task covers:

- a. Removal
- b. Inspection
- c. Cleaning
- d. Installation

**INITIAL SETUP**

**Test Equipment**

None

**References**

None

**Tools**

Tool kit, general mechanics automotive, NSN 5180-00-177-7033

Key, hex drive, 5/32 inch

**Troubleshooting References**

None

**Materials/Parts**

Coupling (Appendix C, item 18, fig. 8)

Spider (Appendix C, item 19, fig. 8)

Key (Appendix C, item 20, fig. 8)

Key (Appendix C, item 21, fig. 8)

Cleaning solvent, P-D-680

**Equipment Condition**

Engine and coupling guard removed for access to coupling.

**Special Environmental Conditions**

Well-ventilated area required when solvent is used.

**General Safety Instructions**

None

**COUPLING (CONT)**

LOCATION/ITEM	ACTION	REMARKS
---------------	--------	---------

**REMOVAL**

- |             |   |  |
|-------------|---|--|
| 1. Setscrew | Use a 5/32 inch hex key to loosen one setscrew in each coupling half. |  |
|-------------|---|--|

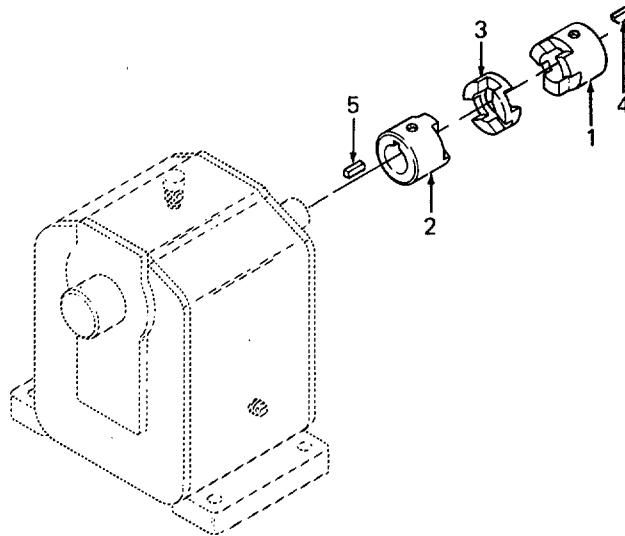

- |                    |   |  |
|--------------------|---|--|
| 2. Coupling halves | Pull coupling half (1) from engine shaft. Remove and discard key (4). Pull coupling half (2) from gear reducer shaft. Remove key (5) from gear reducer shaft. |  |
|--------------------|---|--|

- |           |   |  |
|-----------|---|--|
| 3. Spider | Separate spider (3) from coupling half. |  |
|-----------|---|--|

**INSPECTION**

- |                    |   |  |
|--------------------|---|--|
| 4. Coupling halves | Inspect coupling halves for cracks in metal. Replace coupling if damaged. |  |
|--------------------|---|--|

- |           |  |  |
|-----------|--|--|
| 5. Spider | Inspect for cracks or tears in rubber spider. Replace spider if damaged. |  |
|-----------|--|--|

**COUPLING (CONT)**

LOCATION/ITEM	ACTION	REMARKS
---------------	--------	---------

**CLEANING**

**WARNING**

**Clean parts in a well-ventilated area. Avoid inhalation of solvent fumes and prolonged exposure of skin to cleaning solvent. Wash exposed skin thoroughly. Dry cleaning solvent (fed spec P-D-680) used to clean parts is potentially dangerous to personnel and property. Do not use near open flame or excessive heat. Flash point of solvent is 100° F (38° C).**

- |                               |   |  |
|-------------------------------|---|--|
| 6. Coupling halves and spider | Clean with dry cleaning solvent, P-D-680. Wipe dry. |  |
|-------------------------------|---|--|

**INSTALLATION**

- |                    |   |  |
|--------------------|---|--|
| 7. Coupling halves | <p>Install a new key (4) on engine shaft. Slide coupling half (1) on engine shaft and tighten setscrew with a 5/32 inch hex key.</p> <p>Install key (5) on gear reducer shaft. Slide coupling half (2) on gear reducer shaft and tighten setscrew with a 5/32 inch hex key.</p> |  |
|--------------------|---|--|

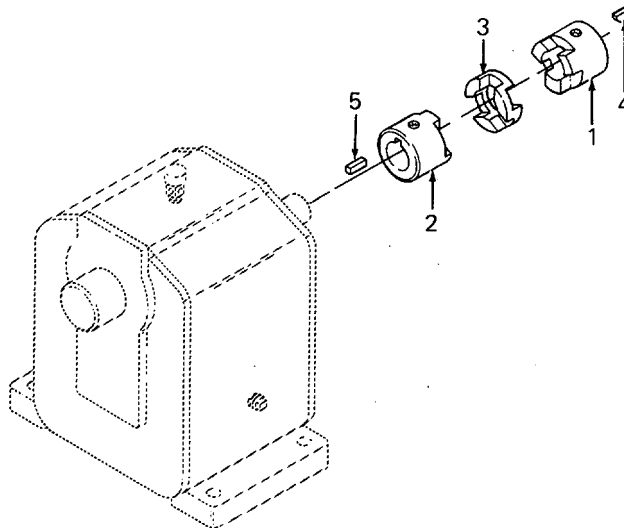

- |           |   |  |
|-----------|---|--|
| 8. Spider | Install spider on gear reducer coupling half. |  |
|-----------|---|--|

**4-26. GEAR REDUCER**

This task covers:

- a. Removal
- b. Inspection
- d. Installation

**INITIAL SETUP**

**Test Equipment**

None

**References**

None

**Tools**

Shop equipment, automotive maintenance and repair, NSN 4910-00-754-0654

Wrench, 15/16 inch

Socket, 15/16 inch and handle

Torque wrench, 0-175 ft lb (0-250 N•m)

**Troubleshooting References**

None

**Equipment Condition**

Engine, coupling guard, and coupling removed for access to gear reducer.

**Special Environmental Conditions**

None

**Materials/Parts**

Gear reducer (Appendix C, item 1, fig. 9)

Loctite (Item 7, Appendix D)

**General Safety Instructions**

None

**GEAR REDUCER (CONT)**

LOCATION/ITEM	ACTION	REMARKS
---------------	--------	---------

**REMOVAL**

- |                       |   |  |
|-----------------------|---|--|
| 1. Cap screw on crank | Use 15/16 inch socket and handle to loosen cap screw (7). Do not remove screw from crank. |  |
|-----------------------|---|--|

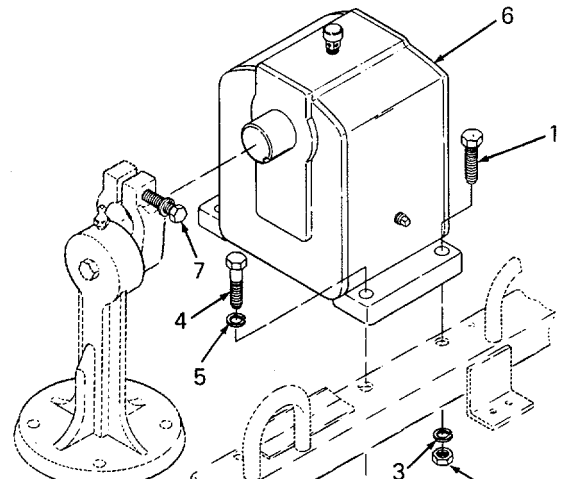

- |                                |  |  |
|--------------------------------|--|--|
| 2. Cap screws closest to crank | Use 15/16 inch socket and handle to remove cap screws (4). Remove two cap screws (4) and lockwashers (5).  |  |
| 3. Cap screws and nuts         | Use 15/16 inch wrench to hold nuts (2). Use 15/16 inch socket and handle to remove cap screws (1). Remove two cap screws (1), nuts (2), and lockwashers (3). |  |
| 4. Gear reducer                | Slide gear reducer (6) away from crank.  |  |

**NOTE**

**It may be necessary to open crank to release gear reducer shaft.**

**INSPECTION**

- |          |  |  |
|----------|--|--|
| 5. Shaft | Check for input and output shaft rotation. If either shaft binds or does not rotate, replace gear reducer. |  |
|----------|--|--|

**GEAR REDUCER (CONT)**

LOCATION/ITEM	ACTION	REMARKS
---------------	--------	---------

**INSTALLATION**

- |                 |   |  |
|-----------------|---|--|
| 6. Gear reducer | Set gear reducer (6) on frame. Slide gear reducer shaft into crank. Align four screw holes in gear reducer and frame. |  |
|-----------------|---|--|

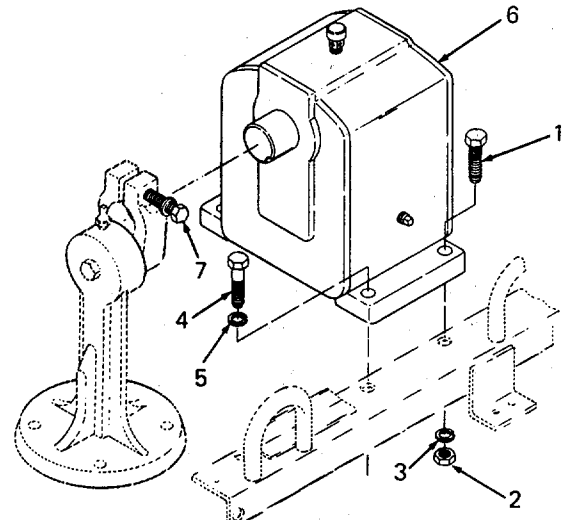

- |                        |   |  |
|------------------------|---|--|
| 7. Cap screws and nuts | Use Loctite on screw threads. Use 15/16 inch wrench to hold nuts (2). Use 15/16 inch socket and handle to install two cap screws (1). Install nuts (2) and lockwashers (3). |  |
|------------------------|---|--|

**NOTE**  
**Do not tighten.**

- |                                |  |  |
|--------------------------------|--|--|
| 8. Cap screws closest to crank | Use Loctite on screw threads. Use 15/16 inch socket and handle to install two cap screws (4). Install lockwashers (5). |  |
|--------------------------------|--|--|

**NOTE**  
**Do not tighten.**

- |                       |   |  |
|-----------------------|---|--|
| 9. Tighten cap screws | Use 15/16 inch socket with a torque wrench to tighten cap screws (1, 4, and 7) to a torque of 75 ft lb (102 N•m). |  |
|-----------------------|---|--|

**Section VII. PREPARATION FOR STORAGE OR SHIPMENT****4-27. GENERAL**

This section provides instructions for preparation of the pump assembly for storage or shipment.

**4-28. ADMINISTRATIVE STORAGE**

a. Placement of equipment in administrative storage should be for short periods of time when a shortage of maintenance effort exists. Items should be in mission readiness within 24 hours or within the time factors as determined by the directing authority. During the storage period appropriate maintenance records will be kept.

b. Before placing equipment in administrative storage, current maintenance services and equipment serviceable criteria (ESC) evaluations should be completed, shortcomings and deficiencies should be corrected, and all modification work orders (MWO's) should be applied.

c. Storage site selection. Inside storage is preferred for items selected for administrative storage. If inside storage is not available, trucks, vans, conex containers and other containers may be used.

**4-29. PACKING AND SHIPPING**

- a. Use shipping plugs, closures, or sealing tape to cover all openings in the pump assembly.
- b. Attach to the pump assembly all forms, tags, and records applicable to the unit.

**CHAPTER 5**

**DIRECT SUPPORT MAINTENANCE INSTRUCTIONS**

This chapter contains the following frequently used maintenance information:

- a. Information on repair parts, special tools, TMDE, and support equipment.
- b. Troubleshooting
- c. Maintenance procedures

The Symptom Index on page 5-2 is a guide to the troubleshooting information. There is also an index to the maintenance procedures on page 5-3.

Section	Title	Page
I	Repair Parts, Special Tools, TMDE, and Support Equipment .....	5-1
II	Troubleshooting . .....	5-2
III	Maintenance Procedures.....	5-3

**Section I. REPAIR PARTS, SPECIAL TOOLS, TMDE, AND SUPPORT EQUIPMENT**

**5-1. COMMON TOOLS AND EQUIPMENT**

For authorized common tools and equipment, refer to the Modified Table of Organization and Equipment (MTOE) applicable to your unit.

**5-2. SPECIAL TOOLS, TMDE, AND SUPPORT EQUIPMENT**

No special tools, TMDE, or support equipment is required for this pump.

**5-3. SPARES AND REPAIR PARTS**

Spares and repair parts are listed and illustrated in Appendix C of this manual.



**Section II. TROUBLESHOOTING**

**5-4. TROUBLESHOOTING**

a. Table 5-1 contains troubleshooting information for locating and correcting most of the operating troubles which are the responsibility of direct support maintenance. Each malfunction for an individual component, unit, or system is followed by a list of tests or inspections which will help you to determine probable causes and corrective actions to take. Perform the tests/inspections and corrective actions in the order listed.

b. This manual cannot list all malfunctions that may occur, nor all tests or inspections and corrective actions. If a malfunction is not listed or is not corrected by listed corrective actions, notify your supervisor.

c. Only those functions within the scope of direct support maintenance are listed. For troubleshooting procedures within the scope of operator/crew maintenance, refer to table 3-1. For troubleshooting procedures within the scope of organizational maintenance, refer to table 4-3.

**5-5. SYMPTOM INDEX**

Refer to the Symptom Index below. Locate the malfunction which is the same, or most nearly the same, as the trouble you are having with the pump assembly. The Symptom Index lists the first page of troubleshooting information for that malfunction. Follow the steps one by one, and perform the corrective actions listed.

Malfunction Number	Description	Page
1	Gear reducer input shaft will not rotate.	5-2
2	Gear reducer output shaft will not rotate.	5-2

**Table 5-1. Direct Support Troubleshooting**

---

**MALFUNCTION**

**TEST OR INSPECTION**

**CORRECTIVE ACTION**

---

1. GEAR REDUCER INPUT SHAFT WILL NOT ROTATE.

Step 1. Check for broken gear or bearing.

Disassemble gear reducer and replace broken parts in accordance with paragraph 5-11.

2. GEAR REDUCER OUTPUT SHAFT WILL NOT ROTATE.

Step 1. Check for broken gear or bearing.

Disassemble gear reducer and replace broken parts in accordance with paragraph 5-11.

---

**Section III. MAINTENANCE PROCEDURES**

**INDEX**

	Para		Para
Accumulator	5-9	Gear Reducer	5-11
Crank and Connecting Rod	5-10	General Instructions	5-6
Discharge Port	5-9	Pump	5-8
Frame Assembly	5-7		

**5-6. GENERAL INSTRUCTIONS**

Most maintenance instructions in this section will list resources required, personnel required, and equipment condition for the start of the procedure. Note the following:

- Resources required are not listed unless they apply to the procedure.
- Personnel required are listed only if the task requires more than one. If PERSONNEL is not listed, it means one person can do the task.
- The normal standard equipment condition to start a maintenance task is engine stopped and cutoff switch off. EQUIPMENT CONDITION is not listed unless some other condition is required besides the power being off.

---

**5-7. FRAME ASSEMBLY**

---

This task covers:

- a. Straightening bent frame.
  - b. Aligning frame.
- 

**INITIAL SETUP**

**Test equipment**

None

**Tools**

Shop equipment, automotive maintenance and repair  
NSN 4910-00-754-0654

**Materials/Parts**

Frame assembly (Appendix C, item 20, fig. 3)

**References**

None

**Troubleshooting References**

None

**Equipment Condition**

Engine, engine guard, coupling guard, gear reducer, pump assembly, wheels, and axle removed for access to frame assembly.

**Special Environmental Conditions**

None

**General Safety instructions**

None

**FRAME ASSEMBLY (CONT)**

LOCATION/ITEM	ACTION	REMARKS
1. Straightening	Straighten distorted or bent structural members of the frame assembly.	<p data-bbox="1047 457 1224 514">10.50 ± 0.015 INCH (266.70 ± 0.38 mm)</p>
2. Aligning	Measure for frame assembly alignment. The mounting holes for the diaphragm clamp must measure 10.50 ± 0.015 inch (266.70 ± 0.38 mm) center-to-center. Align frame assembly if required.	

---

**5-8. PUMP**

---

This task covers:

Thread repair.

---

**INITIAL SETUP****Test equipment**

None

**Tools**

Shop equipment, automotive  
maintenance and repair

NSN 4910-00-754-0654

Tap, 1/2-13 UNC-2B, and handle

Tap, 5/8-11 UNC-2B, and handle

Tap, 1/2 inch NPT, and handle

**Materials/Parts**

Diaphragm clamp (Appendix C, item 5, fig. 7)

Bowl (Appendix C, item 10, fig. 7)

Connecting rod clamp (Appendix C, item 9, fig. 7)

**Personnel Required: 2**

Mechanic will assist in lifting pump.

**References**

None

**Troubleshooting References**

None

**Equipment Condition**

Pump bowl, diaphragm clamp, and clamp  
removed from pump assembly.

**Special Environmental Conditions**

None

**General Safety instructions**

Compressed air for cleaning shall not exceed  
30 psi (207 kPa). Use goggles or face shield  
to prevent eye injury from flying chips.

---

**PUMP (CONT)**

LOCATION/ITEM	ACTION	REMARKS
---------------	--------	---------

1. Bowl

Use 1/2-13 UNC-2B tap and handle to repair threads in holes marked \*.  
Blow out chips with compressed air.

Use 1/2 NPT tap and handle to repair threads in pipe plug hole. Blow out chips with compressed air.

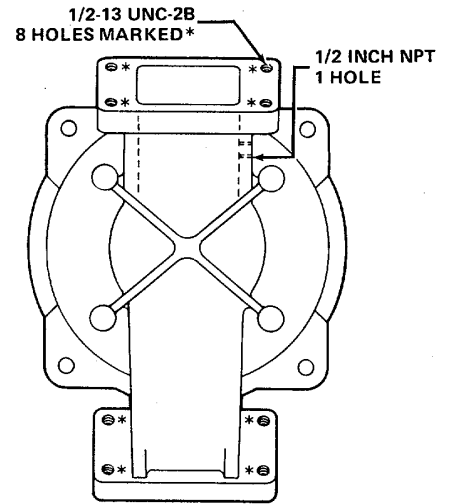

2. Diaphragm clamp

Use 5/8-11 UNC-2B tap and handle to repair threads in diaphragm clamp. Blow out chips with compressed air.

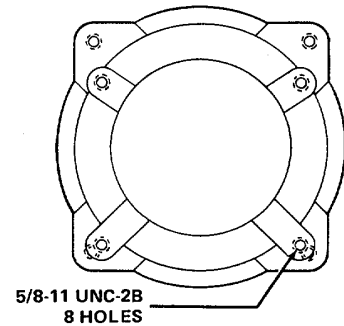

3. Connecting rod clamp

Use 1/2-13 UNC-2B tap and handle to repair threads in holes of clamp. Blow out chips with compressed air.

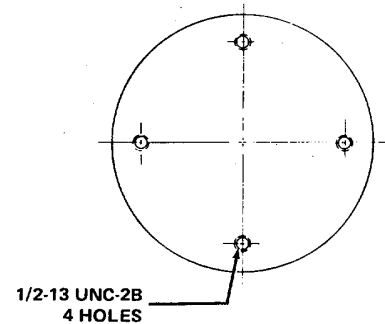

---

**5-9. ACCUMULATOR AND DISCHARGE PORT**

---

This task covers:

Thread repair.

---

**INITIAL SETUP****Test equipment**

None

**Tools**

Shop equipment, automotive  
maintenance and repair

NSN 4910-00-754-0654

Tap, 2 inch NPT, and handle

Tap, 4 inch NPT, and handle

**Materials/Parts**

Accumulator (Appendix C, item 5, fig. 6)

Discharge port (Appendix C, item 9, fig. 6)

**Personnel Required: 2**

Mechanic will assist in lifting accumulator.

**References**

None

**Troubleshooting References**

None

**Equipment Condition**

Accumulator and discharge port  
removed from pump assembly.

**Special Environmental Conditions**

None

**General Safety instructions**

Compressed air for cleaning shall not exceed  
30 psi (207 kPa). Use goggles or face shield  
to prevent eye injury from flying chips.

**ACCUMULATOR AND DISCHARGE PORT (CONT)**

LOCATION/ITEM	ACTION	REMARKS
---------------	--------	---------

1. Accumulator Use 2 inch NPT tap and handle to repair threads in accumulator pipe plug hole. Blow out chips with compressed air.

Use 4 inch NPT tap and handle to repair threads in accumulator pipe nipple hole. Blow out chips with compressed air.

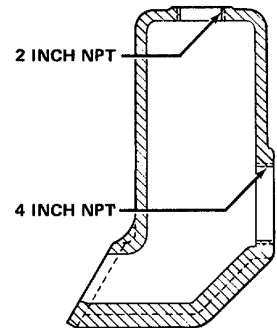

2. Discharge port Use 4 inch NPT tap and handle to repair threads in pipe nipple hole. Blow out chips with compressed air.

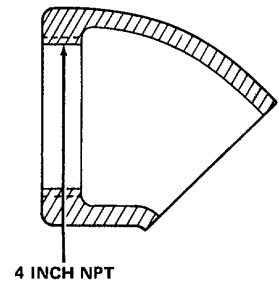



---

**5-10. CRANK AND CONNECTING ROD**

---

This task covers:

- a. Bearing replacement.
  - b. Inner race replacement.
  - c. Thread repair.
- 

**INITIAL SETUP****Test equipment**

None

**Tools**

Shop equipment, automotive maintenance and repair  
NSN 4910-00-754-0654

Puller, mechanical, gear and bearing

Tap, 5/8-11 UNC-2B, and handle

**Materials/Parts**

Crank (Appendix C, item 12, fig. 8)

**References**

None

---

**Troubleshooting References**

None

**Equipment Condition**

Crank removed from drive.

**Special Environmental Conditions**

None

**General Safety instructions**

Compressed air for cleaning shall not exceed 30 psi (207 kPa). Use goggles or face shield to prevent eye injury from flying chips.

**CRANK AND CONNECTING ROD (CONT)**

LOCATION/ITEM	ACTION	REMARKS
---------------	--------	---------

**DISASSEMBLY**

- |               |   |
|---------------|---|
| 1. Bearing    | Remove roller bearing (2) from connecting rod (1).                                |
| 2. Inner race | Use a mechanical gear and bearing puller to remove inner race (4) from crank (3). |

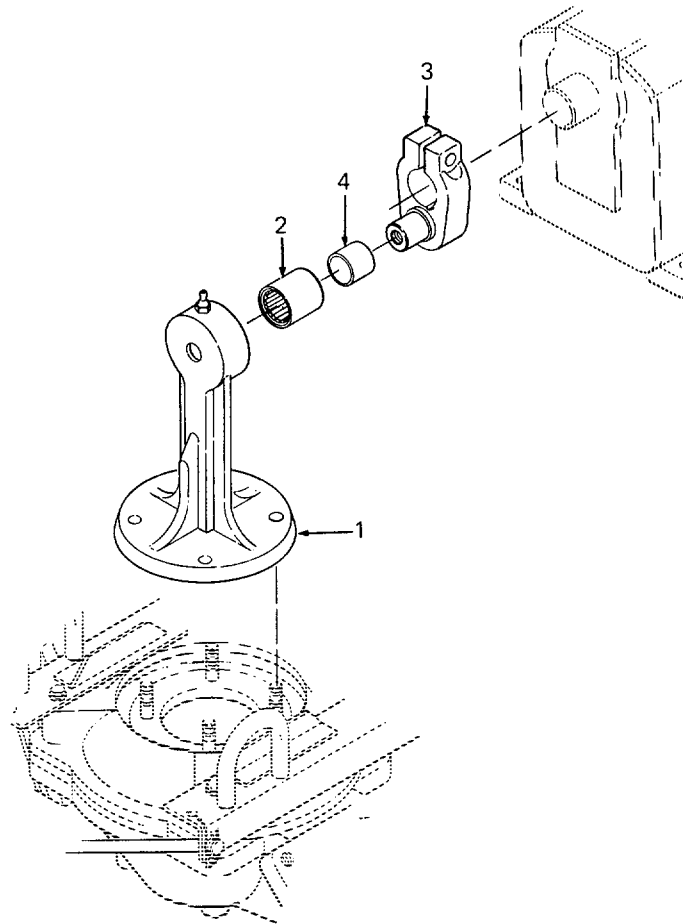

**CRANK AND CONNECTING ROD (CONT)**

LOCATION/ITEM	ACTION	REMARKS
---------------	--------	---------

**REPAIR**

3. Crank

Use 5/8-11 UNC-2B tap and handle to repair threads. Blow out-chips with compressed air.

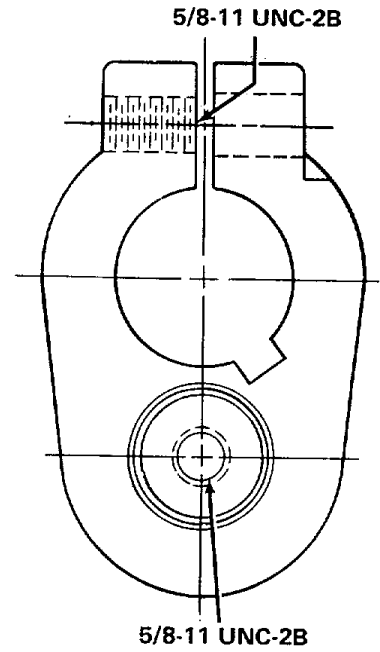

**CRANK AND CONNECTING ROD (CONT)**

LOCATION/ITEM	ACTION	REMARKS
---------------	--------	---------

**ASSEMBLY**

- 4. Bearing  
Use an arbor press to install bearing (2) into connecting rod (1).
- 5. Inner race  
Use an arbor press to install inner race (4) on crank (3).

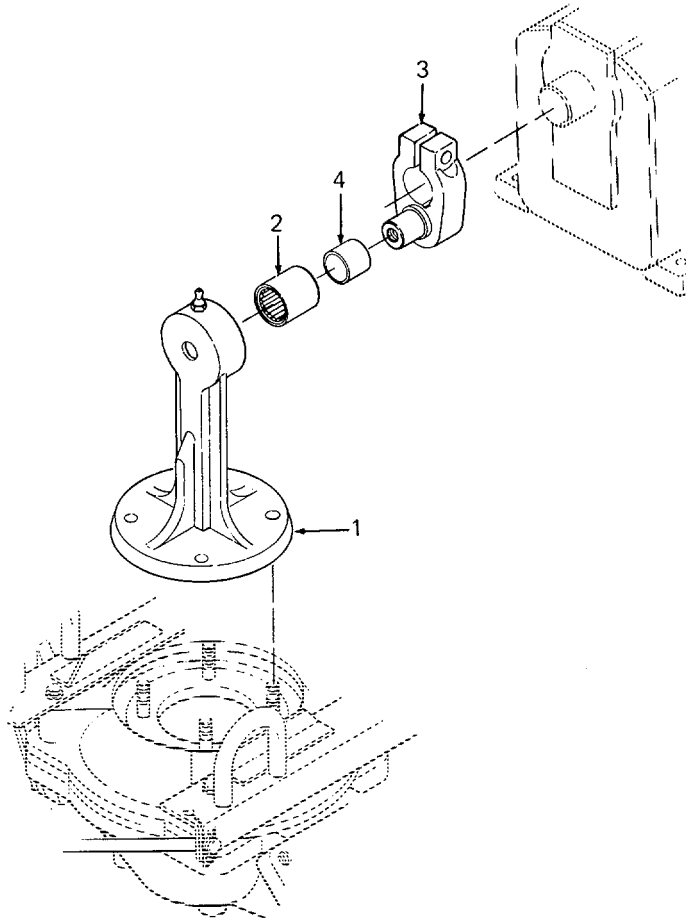

**5-11. GEAR REDUCER**

This task covers:

- a. Disassembly
- b. Inspection
- c. Cleaning
- d. Assembly

**INITIAL SETUP**

**Test equipment**

None

**Tools**

Shop equipment, automotive maintenance and repair  
NSN 4910-00-754-0654

- Wrench, 7/16 inch
- Wrench, 3/8 inch
- Wrench, 9/16 inch, or
- Socket, 9/16 inch, and handle
- Screwdriver, 1/4 inch blade
- Puller, mechanical, gear and bearing
- Pliers, retaining ring
- Pliers, hose clamp
- Torque wrench, 0-175 ft lb (0-250 N•m)  
NSN 5120-00-640-6364
- Drain pan
- Arbor press

**Materials/Parts**

- Gear reducer (Appendix C, item 1, fig. 9)
- Cleaning solvent, P-D-680
- Loctite No. 242 (05972)
- Sealer, Silmate No. A689005AA-006 (02787)
- Lubricating oil, gear, multipurpose, MIL-M-2105, Grade 90
- Grease, ball and roller bearing, MIL-G-187/69

**References**

None

**Troubleshooting References**

- Malfunction 1, step .1
- Malfunction 2, step 1

**Equipment Condition**

Gear reducer removed from pump assembly

**Special Environmental Conditions**

Well-ventilated area required when solvent is used.

**General Safety instructions**

None

**GEAR REDUCER (CONT)**

LOCATION/ITEM	ACTION	REMARKS
---------------	--------	---------

**DISASSEMBLY**

1. Drain oil

Drain oil into drain pan. Use 3/8 inch wrench to remove drain plug (1). Use 7/16 inch wrench to remove level plug (2) and breather (3).

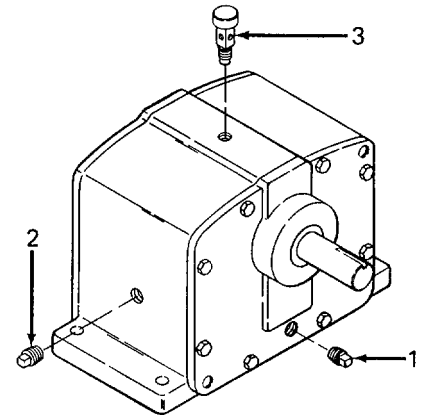

2. Output cover

Use 9/16 inch socket and handle to remove eight cap screws (1). Remove output cover (2). Remove and discard output seal (3).

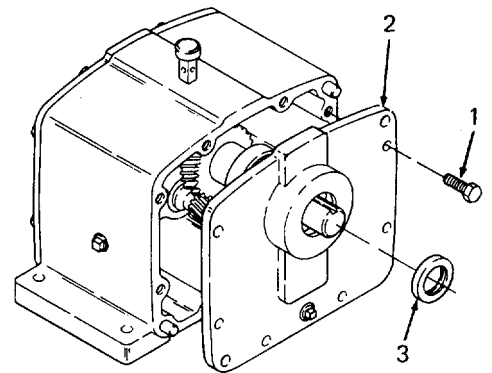

3. Output shaft

Remove output shaft from gear reducer as an assembly. Use gear and bearing mechanical puller to remove outboard bearing (1) and inboard bearing (2) from output shaft (6). Remove spacer (3).

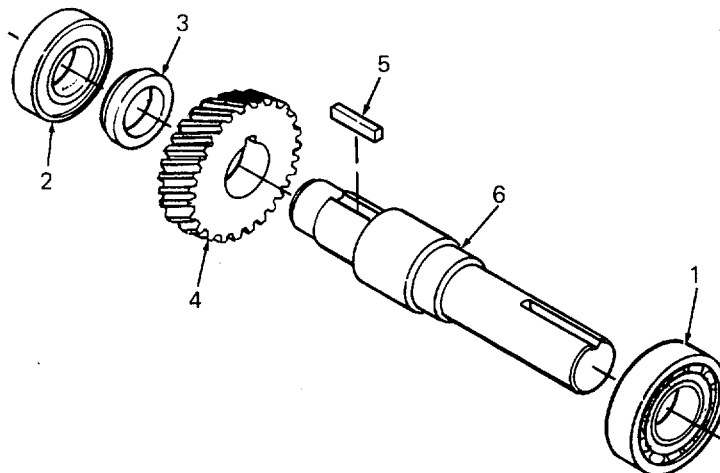

**GEAR REDUCER (CONT)**

LOCATION/ITEM	ACTION	REMARKS
---------------	--------	---------

- |                |  |  |
|----------------|--|--|
| 4. Gear        | Use gear and bearing mechanical puller to remove gear (4) from output shaft (6). Remove key (5).                           |  |
| 5. Input cover | Use 9/16 inch socket and handle to remove eight cap screws (1). Remove input cover (2). Remove and discard input seal (3). |  |

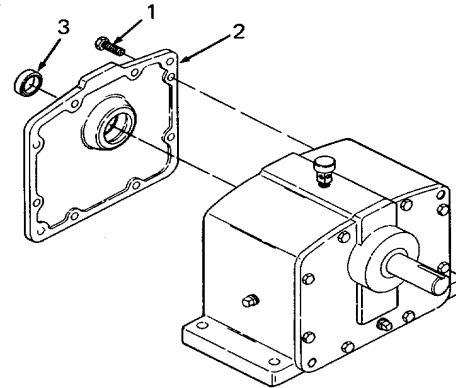

- |                |  |  |
|----------------|--|--|
| 6. Input shaft | Use retaining ring pliers to remove snap ring (1) from input cover (2). Remove input shaft (5) with bearings (3 and 4) from input cover (2). |  |
|----------------|--|--|

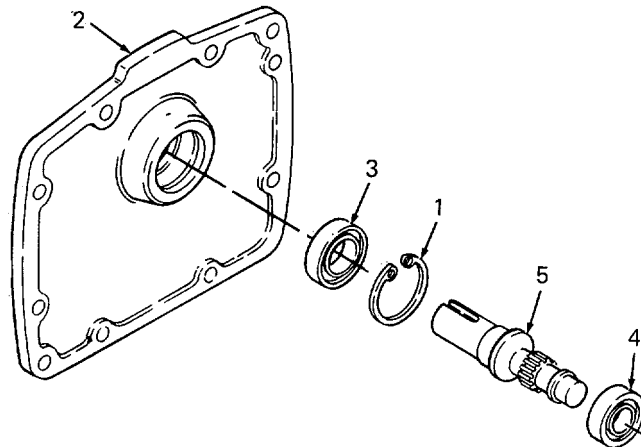

- |             |  |  |
|-------------|--|--|
| 7. Bearings | Use gear and bearing mechanical puller to remove input cover bearing (3) and input bearing (4) from input shaft (5). |  |
|-------------|--|--|

**NOTE**

**Pinion and input shaft are a permanent assembly. Do not attempt to separate them.**

**GEAR REDUCER (CONT)**

LOCATION/ITEM	ACTION	REMARKS
---------------	--------	---------

- |         |   |  |
|---------|---|--|
| 8. Gear | Use screwdriver to press tang of lockwasher (2) away from locknut (1). Use hose clamp pliers to remove locknut (1). Remove lockwasher (2). Use gear and bearing mechanical puller to remove gear and bearing (3). |  |
|---------|---|--|

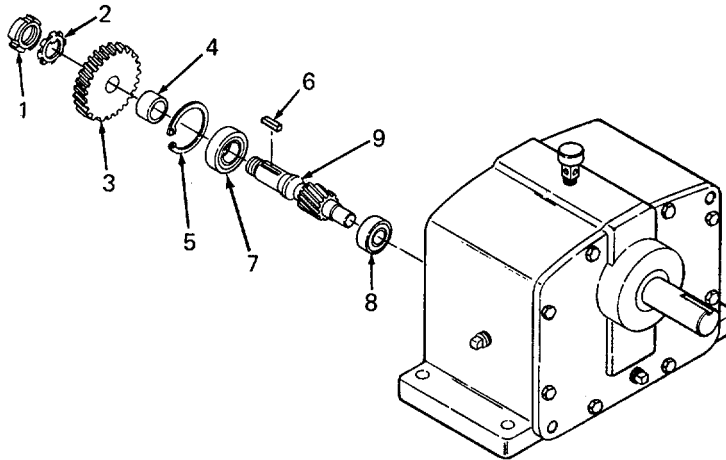

- |                             |   |  |
|-----------------------------|---|--|
| 9. Jackshaft spacer and key | Remove key (6) from jackshaft (9). Remove jackshaft spacer (4).   |  |
| 10. Jackshaft               | Use retaining ring pliers to remove snap ring (5) from groove in reducer housing bore. Remove jackshaft (9), bearing (7), and bearing (8) as an assembly. |  |
| 11. Bearings                | Use gear and bearing mechanical puller to remove bearings (7 and 8) from jackshaft (9).   |  |

**INSPECTION**

- |                               |   |  |
|-------------------------------|---|--|
| 12. Covers                    | Inspect input and output covers for cracks and warpage. Replace if damaged.                       |  |
| 13. Output shaft              | Inspect for damaged keyways and galled bearing journals. Replace if damaged.                      |  |
| 14. Input shaft and jackshaft | Inspect for damaged keyways, galled bearing journals, and damaged gear teeth. Replace if damaged. |  |



---

**GEAR REDUCER (CONT)**

---

LOCATION/ITEM	ACTION	REMARKS
15. Bearings	Bearings must turn freely without binding. Inspect for brinelled or burnished areas. Replace damaged bearing.	
16. Gears	Inspect for chipped-or eroded gear teeth. Any evidence of gear tooth damage will require gear replacement.	

**CLEANING**

**WARNING**

**Clean parts in a well-ventilated area. Avoid inhalation of solvent fumes and prolonged exposure of skin to cleaning solvent. Wash exposed skin thoroughly. Dry cleaning solvent (fed spec P-D-680) used to clean parts is potentially dangerous to personnel and property. Do not use near open flame or excessive heat. Flash point of solvent is 100° F (38° C).**

17. Covers and gear housing	Clean with cleaning solvent, P-D-680. Use a stiff-bristle brush to remove caked dirt. After cleaning wipe all bearing bores with light oil.
18. Bearings	

**CAUTION**

**Do not spin bearing when cleaning. Damage can result from spinning.**

19. Input shaft, output shaft, jackshaft, and gears	Soak the bearings in dry cleaning solvent, P-D-680, and use a soft-bristle brush to remove old grease. After cleaning, dip the bearing in light oil and wrap in lint-free paper until ready to assemble.  Wash in dry cleaning solvent, P-D-680. Use a soft-bristle brush to remove old grease. After cleaning, wipe with light oil and wrap in lint-free paper until ready to assemble.
---	--

**GEAR REDUCER (CONT)**

LOCATION/ITEM	ACTION	REMARKS
---------------	--------	---------

**ASSEMBLY**

**NOTE**

**Prior to assembly, pack all bearings in grease, MIL-G-18709.**

- |              |  |
|--------------|--|
| 20. Bearings | Using an arbor press, install bearings (7 and 8) on jackshaft (9). |
|--------------|--|

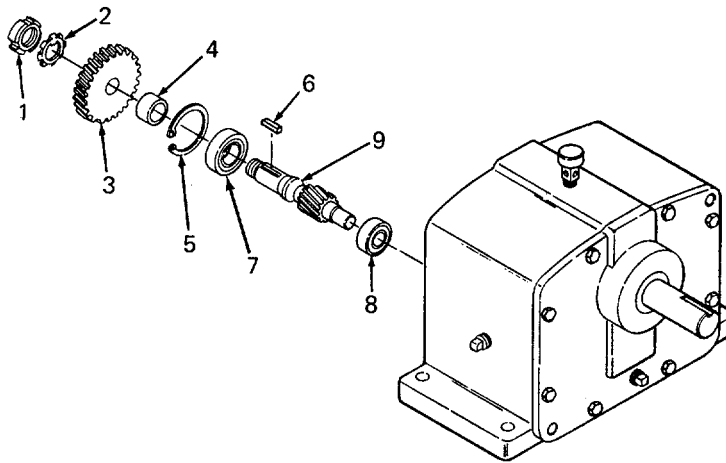

- |                              |  |
|------------------------------|--|
| 21. Jackshaft                | Insert jackshaft (9) with bearings (7 and 8) through gear housing web from the input side. Press jackshaft (9) until bearing (7), is seated past the snap ring groove. Use retaining ring pliers to install snap ring (5).   |
| 22. Jackshaft spacer and key | Slide jackshaft spacer (4) over jackshaft and against bearing (7). Install key (6) into jackshaft keyway.  |
| 23. Gear on jackshaft        | Align keyway in gear (3) with key (6), and press gear on jackshaft (9). Slide keyed lockwasher (2) on jackshaft. Apply Loctite No. 242 on threads of locknut (1) and install locknut. When locknut is snug against lockwasher, align a flat of the locknut with a tang of the lockwasher. Bend tang over locknut flat. |

GEAR REDUCER (CONT)

LOCATION/ITEM	ACTION	REMARKS
---------------	--------	---------

- |                             |  |  |
|-----------------------------|--|--|
| 24. Bearings on input shaft | Using an arbor press, install bearings (3 and 4) on input shaft (5). |  |
|-----------------------------|--|--|

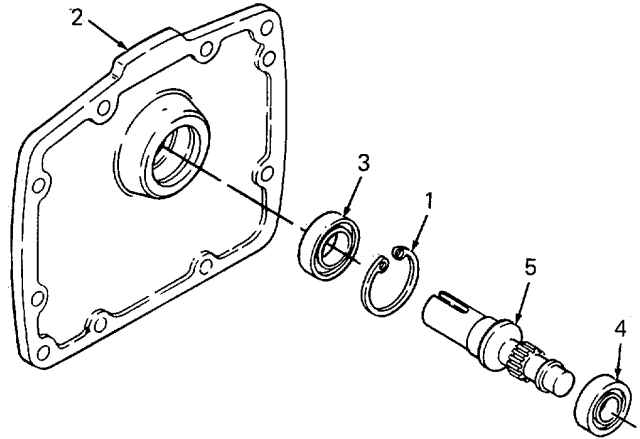

- |                 |   |  |
|-----------------|---|--|
| 25. Input shaft | Insert input shaft (5) with bearings (3 and 4) into and through input cover (2). Press input cover bearing (3) into input cover (2) until it is seated past snap ring groove. Use retaining ring pliers to install snap ring (1). |  |
|-----------------|---|--|

- |                 |   |  |
|-----------------|---|--|
| 26. Input cover | Coat mounting face of input cover (2) with sealer, Silmate No. A689005AA-006. Assemble input cover (2) to gear housing. |  |
|-----------------|---|--|

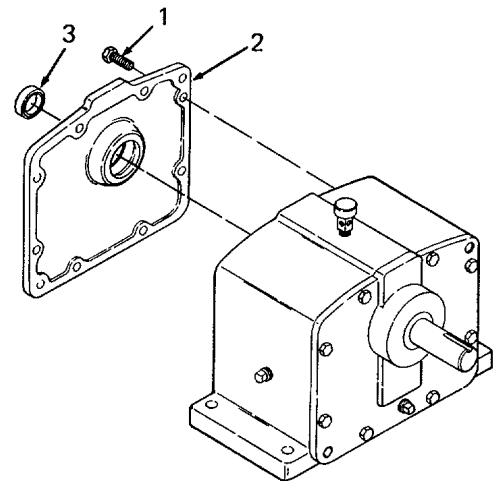

**NOTE**

**Engage input shaft gear with jackshaft gear when installing input cover.**

Apply Loctite No. 242 to threads of eight cap screws (1). Use 9/16 inch socket and torque wrench to tighten cap screws to 31 ft lb (42 N•m). Pack grease, MIL-G-18709, in input bearing cavity in input cover (2) and install new seal (3) flush with input cover face.

**GEAR REDUCER (CONT)**

LOCATION/ITEM	ACTION	REMARKS
---------------	--------	---------

27. Gear on output shaft

Install key (5) into keyway of output shaft (6). Align keyway in gear (4) with key (5), and press gear on output shaft (6) until it bottoms against the shaft shoulder.

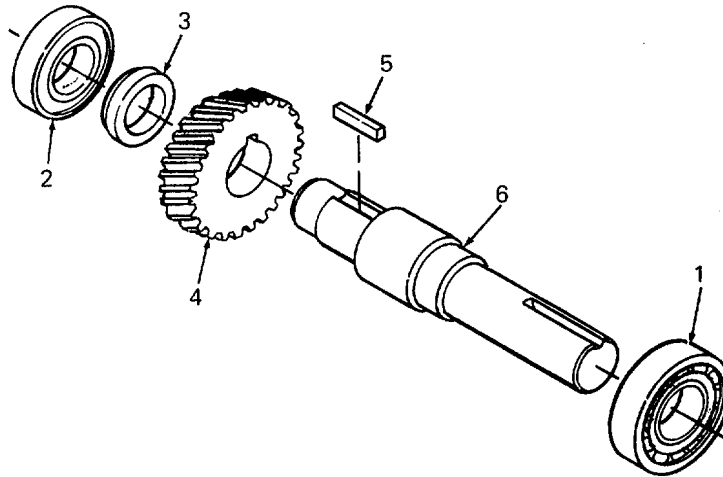

28. Output shaft

Install spacer (3) against gear (4). Press inboard bearing (2) on output shaft (6) and against spacer (3). Press outboard bearing (1) on output shaft until it bottoms against the output shaft shoulder.

29. Install output shaft

Install output shaft assembly into gear housing until inboard bearing (2) bottoms on shoulder of bearing bore.

**NOTE**

**Engage output shaft gear with jackshaft gear.**

30. Output cover

Coat output cover (2) mounting face with sealer, Silmate No. A689005AA-006. Assemble output cover to gear housing. Apply Loctite No. 242 to threads of eight cap screws (1).

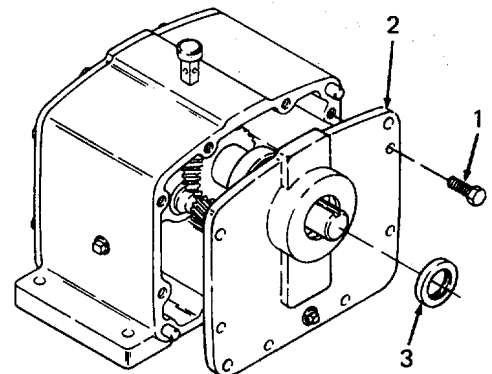

**GEAR REDUCER (CONT)**

LOCATION/ITEM	ACTION	REMARKS
---------------	--------	---------

**CAUTION**

Align bearing bores with bearings being careful not to cock either bearing bore. Tighten cap screws evenly and with equal torque.

Use 9/16 inch socket and torque wrench to tighten cap screws to 31 ft lb (42 N.m). Pack grease, MIL-G-18709, in output bearing cavity in output cover (2) and install new seal (3) flush with output cover face.

31. Fill with oil

Use 3/8 inch wrench to install drain plug (1). Fill gear reducer through breather (3) hole with lubricating oil, MIL-M-2105, Grade 90, until oil starts to flow from level plug hole. Use 7/16 inch wrench to install level plug (2). Install breather (3).

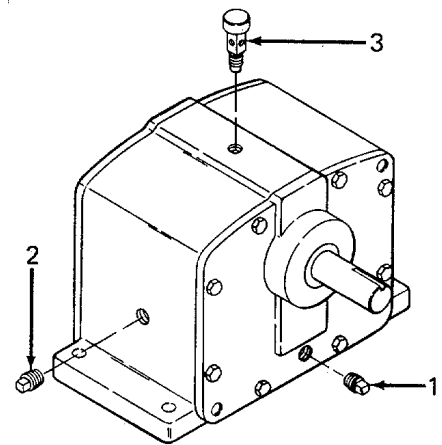

**APPENDIX A  
REFERENCES**

---

**A-1. SCOPE**

This appendix lists all forms, field manuals, and technical manuals referenced in this manual.

**A-2. FORMS**

Quality Deficiency Report .....SF 368  
 Recommended Changes to Publications and Blank Forms ..... DA 2028

**A-3. TECHNICAL MANUALS**

Operator's, Organizational, Direct Support and General Support Maintenance:  
     Engine, Gasoline, 3HP, Military Standard Models ..... TM 5-2805-257-14  
 Organizational, Intermediate (Field) Direct and General Support and  
     Depot Maintenance Repair Parts and Special Tools List:  
     Engine, Gasoline, 3HP, Military Standard Models ..... TM 5-2805-257-24P  
 Procedures for Destruction of Equipment to Prevent Enemy Use ..... TM 750-244-3  
 The Army Maintenance Management System ..... DA PAM 738-750

**A-4. MISCELLANEOUS PUBLICATIONS**

Lubrication Order: Pump, Reciprocating, Power-Driven, Diaphragm, Gasoline-Engine-Driven,  
     Wheel Mounted, US40CDG ..... LO 5-4320-275-12

## APPENDIX B MAINTENANCE ALLOCATION CHART

---

### Section I. INTRODUCTION

#### B-1. MAINTENANCE ALLOCATION CHART (MAC)

a. *General.* This MAC assigns maintenance functions in accordance with the Three Level Maintenance concept. The three levels are depicted on the MAC as:

UNIT level-corresponds to an O code in the Repair Parts and Special Tools List (RPSTL). A C code entry under UNIT denotes maintenance performed by the crew or operator within UNIT maintenance.

INTERMEDIATE level-corresponds to an F or H code in the RPSTL.

DEPOT level-corresponds to a D code in the RPSTL.

b. *Unit Maintenance.* Maintenance to be performed in the Unit level is described as follows:

(1) Unit Maintenance activities are staffed and equipped to perform high frequency on-equipment maintenance tasks required to retain or return equipment to a serviceable condition. These tasks include preventive maintenance and repair and replace functions associated with a high level of mission capability.

(2) Unit Maintenance inspection and servicing include daily (usually performed by operator or crew), periodic, and special inspections, as authorized by the MAC or higher headquarters.

(3) Unit level maintains a Combat Prescribed Load List (PLL) which consists of items on the Mandatory Parts List (MPL) and items which are demand supported.

(4) Unit level performs troubleshooting, replace, and limited repair functions as authorized by the MAC, RPSTL, and applicable technical manuals.

c. *Intermediate Maintenance.* Maintenance to be performed in the Intermediate level is described as follows:

(1) One stop maintenance support through use of mobile weapon system oriented maintenance teams to perform authorized maintenance (that exceeds Unit level capability) to effect quick repair and return to user capabilities.

(2) Maintains a Combat Authorized Stockage List (ASL), Mandatory Parts List (MPL), Direct Exchange (DX), and provides limited Operational Readiness Float (ORF) for supported units.

(3) Provides collection, classification, and recovery services for serviceable and unserviceable materiel and maintains a Battle Damage Assessment (BDA) capability.

(4) Provides maintenance support for the theater supply system through repair of components and DX items.

(5) Provides maintenance units composed of commodity oriented platoons which may be augmented by support teams that deploy forward if the tactical situation permits.

(6) Maintains Operational Readiness Float (ORF) stocks in support of the theater.

d. *Depot Maintenance.* Depot level functions are authorized as indicated by entries in the Depot (D) Maintenance level column (4) in the MAC.

## **B-2. USE OF THE MAINTENANCE ALLOCATION CHART, SECTION II**

a. The MAC assigns maintenance functions based on the following considerations:

- (1) Skills available.
- (2) Work time required.
- (3) Tools and test equipment required and/or available.

b. If a lower level of maintenance identified in column (4) of the MAC cannot perform all tasks of a single maintenance function (e.g., test, repair), then the higher level that can perform other tasks of that function is also indicated.

c. Higher maintenance levels are automatically authorized to perform maintenance functions assigned to a lower maintenance level.

d. Higher maintenance levels will perform the maintenance functions of lower maintenance levels when required or directed by the Commander who has authority to direct such tasking.

e. Assignment of a maintenance function in the MAC does not carry automatic authorization to carry the related spare or repair parts in stock. Information to requisition or secure parts will be as specified in the associated RPSTL.

f. Normally, there will be no deviation from the assigned level of maintenance. However, in cases of operational necessity, maintenance functions assigned a higher level may, at the request of the lower level, be assigned to the lower level on a one-time basis, if specifically authorized by the maintenance officer of the higher level to which the function is assigned. In such a case, the special tools, equipment, etc., required by the lower level to perform this function will be furnished by the higher level assigned the function. Also, transfer of a function to a lower level does not relieve the higher level of responsibility for the function, so the higher level will provide technical supervision and inspection of the function being performed at the lower level.

## **B-3. MAINTENANCE FUNCTIONS**

Maintenance functions will be limited to and defined as follows:

a. *Inspect.* Two levels of inspect are covered in the MAC.

(1) When prescribed at the C or O element of Unit Maintenance level, inspect means to determine serviceability by comparing an item's physical, mechanical, and/or electrical characteristics with established standards through examination (i.e., by sight, sound, or feel). These inspections are included in preventive maintenance (PM) checks and services, such as PMCS, PMD.

(2) When prescribed at the Intermediate (F) or Depot (D) maintenance level, inspect refers to an initial inspection which is conducted prior to scheduling any repair on repairable items evacuated to this level. This inspection is made to determine whether an item qualifies for repair or discard.

b. *Test.* To verify serviceability and detect incipient failure by measuring the mechanical or electrical characteristics of an item and comparing those characteristics with prescribed standards.



c. *Service*. Operations required periodically to keep an item in proper operating condition, i.e., to clean (includes decontaminate), to preserve, to drain, or to replenish fuel, lubricants, hydraulic fluids, or compressed air supplies.

d. *Adjust*. To maintain within prescribed limits, by bringing into proper or exact position, or by setting the operating characteristics to the specified parameters.

e. *Align*. To adjust specified variable elements of an item to bring about optimum or desired performance.

f. *Calibrate*. To determine and cause corrections to be made or to be adjusted on instruments or test measuring and diagnostic equipment used in precision measurement. Consists of comparison of two instruments, one of which is a certified standard of known accuracy, to detect and adjust any discrepancy in the accuracy of the instrument being compared.

g. *Install*. The act of emplacing, seating, or fixing into position an item, part, or module (component or assembly) in a manner to allow the proper functioning of an equipment or system.

h. *Replace*. The act of substituting a serviceable like type part, a subassembly, or module (component or assembly) for an unserviceable counterpart.

i. *Repair*. The application of maintenance services (inspect, test, service, adjust, align, calibrate, or replace) or other maintenance actions (welding, grinding, riveting, straightening, facing, remachining, or resurfacing) to restore serviceability to an item by correcting specific damage, fault, malfunction, or failure in a part, subassembly, module (component or assembly), end item, or system.

j. *Overhaul*. That maintenance effort (service/action) necessary to restore an item to a completely serviceable operational condition as prescribed by maintenance standards in appropriate technical publications (i.e., DMWR). Overhaul is normally the highest degree of maintenance performed by the Army. Overhaul does not normally return an item to a like new condition.

k. *Rebuild*. Consists of those services/actions necessary for the restoration of unserviceable equipment to a like new condition in accordance with original manufacturing standards. Rebuild is the highest degree of materiel maintenance applied to Army equipment. The rebuild operation includes the act of returning to zero those age measurements (hours/miles, etc.) considered in classifying Army equipment/components.

#### **B-4. EXPLANATION OF COLUMNS IN THE MAC, SECTION II**

a. *Column (1), Group Number*. Column 1 lists functional group code numbers which are assigned to identify maintenance significant components, assemblies, subassemblies, and modules to their next higher assembly.

b. *Column (2), Component/Assembly*. Column 2 contains the item names of components, assemblies, subassemblies, and modules for which group numbers (column 1) are assigned and for which maintenance is authorized.

c. *Column (3), Maintenance Function*. Column 3 lists the functions to be performed on items listed in column 2. (Function definitions are contained in paragraph B-3.)

d. *Column (4), Maintenance Level.* The maintenance levels, Unit, Intermediate, and Depot, are allotted separate subcolumns within column 4. Entry of a work time figure (such as 1.0, 0.2) in a subcolumn indicates that that level is authorized to perform the function listed in column 3, and the average time required to do the function is the work time figure. If the number or complexity of tasks within a maintenance function varies from one maintenance level to another, the applicable work time figure for each level will be entered for that function. The work time figure represents the average time it takes to restore a component/assembly to a serviceable condition under a typical field operating environment.

e. *Column (5), Tools and Equipment.* Column 5 specifies, by code, common tool sets (not individual tools from those sets), common TMDE, and special tools, TMDE, and support equipment required to perform a designated function. The code in Column 5 keys to the listing in Section III of the MAC.

f. *Column (6), Remarks.* This column, when applicable, contains a letter code which is keyed to an explanation of the code contained in Section IV of the MAC.

**B-5. EXPLANATION OF COLUMNS IN THE MAC, SECTION III**

a. *Column (1), Tool or Test Equipment Reference Code.* The tool or test equipment reference code correlates with a code used in the MAC, Section II, Column 5.

b. *Column (2), Maintenance Category.* The lowest category of maintenance authorized to use the tool or test equipment.

c. *Column (3), Nomenclature.* Name or identification of the tool or test equipment.

d. *Column (4), National/NATO Stock Number.* The national stock number of the tool or test equipment.

e. *Column (5), Tool Number.* The manufacturer's part number.

**B-6. EXPLANATION OF COLUMNS IN THE MAC, SECTION IV**

a. *Column (1), Reference Code.* The code recorded in Column 6, Section II.

b. *Column (2), Remarks.* This column lists information pertinent to the maintenance function being performed as indicated in the MAC, Section II.

Section II. MAINTENANCE ALLOCATION CHART

(1) Group Number	(2) Component/ Assembly	(3) Maintenance Function	(4) Maintenance Level					(5) Tools and Equipment	(6) Remarks
			C	O	F	H	D		
01	ENGINE								
0100	Engine Assembly  (See TM5-2805-257-14)	Inspect Service Replace Repair	0.2	1.0 1.0	16			1 1 1	A
02	FUEL SYSTEM								
0200	Tank, Line, Fittings, & Filter	Inspect Service Replace	0.2 0.2	0.5				1 1	
03	FRAME								
0300	Wheel Assembly	Inspect Service Replace	0.2 0.2	1.0				1	
0301	Frame Assembly	Inspect Service Replace Repair	0.2 0.2	1.0	2.0			1 2	
04	ACCESSORY ITEMS								
0400	Data Plates	Inspect Replace	0.2	2.0				2	
0401	Suction Lines	Inspect Replace	0.2	0.1					

Section II. MAINTENANCE ALLOCATION CHART-Continued

(1) Group Number	(2) Component/ Assembly	(3) Maintenance Function	(4) Maintenance Level					(5) Tools and Equipment	(6) Remarks
			C	O	F	H	D		
05	PUMP								
0500	Accumulator, Check Valve Assemblies, & Discharge Port	Inspect Service Replace Repair	0.2 0.4	2.0	3.0			2 2	
0501	Diaphragm, Connecting Rod Assembly, & Gear Reducer	Inspect Service Replace Repair	0.2	1.0 1.0	3.0			2 2 2	

APPENDIX C

ORGANIZATIONAL AND DIRECT SUPPORT  
MAINTENANCE REPAIR PARTS AND SPECIAL TOOLS LIST

Section I. INTRODUCTION

C-1. SCOPE

This manual lists spares and repair parts; special tools; special test, measurement, and diagnostic equipment (TMDE), and other special support equipment required for performance of organizational and direct support maintenance of the US40CDG pump. It authorizes the requisitioning and issue of spares and repair parts as indicated by the source and maintenance codes.

C-2. GENERAL

This Repair Parts and Special Tools List is divided into the following sections:

a. *Section II. Repair Parts List.* A list of spares and repair parts authorized for use in the performance of maintenance. The list also includes parts which must be removed for replacement of the authorized parts. Parts lists are composed of functional groups in numeric sequence, with the parts in each group listed in figure and item number sequence. Bulk materials are listed in NSN sequence.

b. *Section III. Special Tools List.* A list of special tools, special TMDE, and other special support equipment authorized for the performance of maintenance.

c. *Section IV. National Stock Number and Part Number Index.* A list, in National item identification number (NIIN) sequence, of all National stock numbers (NSN) appearing in the listings, followed by a list in alphameric sequence of all part numbers appearing in the listings. National stock numbers and part numbers are cross-referenced to each illustration figure and item number appearance.

C-3. EXPLANATION OF COLUMNS

a. *Illustration.* This column is divided as follows:

(1) *Figure Number.* Indicates the figure number of the illustration on which the item is shown.

(2) *Item Number.* The number used to identify item called out in the illustration.

b. *Source, Maintenance, and Recoverability (SMR) Codes.*

(1) *Source Code.* Source codes indicate the manner of acquiring support items for maintenance, repair, or overhaul of end items. Source codes are entered in the first and second positions of the Uniform SMR Code format as follows:

<i>Code</i>	<i>Definition</i>
PA	- Item procured and stocked for anticipated or known usage.
PB	- Item procured and stocked for insurance purpose because essentiality dictates that a minimum quantity be available in the supply system.
PC	- Item procured and stocked and which otherwise would be coded PA except that it is deteriorative in nature.

<i>Code</i>	<i>Definition</i>
PD	- Support item, excluding support equipment, procured for initial issue or outfitting, and stocked only for subsequent or additional initial issues or outfittings. Not subject to automatic replenishment.
PE	- Support equipment procured and stocked for initial issue or outfitting to specified maintenance repair activities.
PF	- Support equipment which will not be stocked but which will be centrally procured on demand.
PG	- Item procured and stocked to provide for sustained support for the life of the equipment. It is applied to an item peculiar to the equipment which, because of probable discontinuance or shutdown of production facilities, would prove uneconomical to reproduce at a later time.
KD	- An item of a depot overhaul/repair kit and not purchased separately. Depot kit defined as a kit that provides items required at the time of overhaul or repair.
KF	- An item of a maintenance kit and not purchased separately. Maintenance kit defined as a kit that provides an item that can be replaced at organizational or intermediate levels of maintenance.
KB	- Item included in both a depot overhaul/repair kit and a maintenance kit.
MO	- Item to be manufactured or fabricated at organizational level.
MF	- Item to be manufactured or fabricated at the direct support maintenance level.
MH	- Item to be manufactured or fabricated at the general support maintenance level.
MD	- Item to be manufactured or fabricated at the depot maintenance level.
AO	- Item to be assembled at organizational level.
AF	- Item to be assembled at direct support maintenance level.
AH	- Item to be assembled at general support maintenance level.
AD	- Item to be assembled at depot maintenance level.
XA	- Item is not procured or stocked because the requirements for the item will result in the replacement of the next higher assembly.
XB	- Item is not procured or stocked. If not available through salvage, requisition.
XC	- Installation drawing, diagram, instruction sheet, field service drawing, that is identified by manufacturer's part number.
XD	- A support item that is not stocked. When required, item will be procured through normal supply channels.

**NOTE**

**Cannibalization or salvage may be used as a source of supply for any items coded above except those coded XA and aircraft support items as restricted by AR 700-42.**

(2) *Maintenance Code.* Maintenance codes are assigned to indicate the levels of maintenance authorized to USE and REPAIR support items. The maintenance codes are entered in the third and fourth positions of the Uniform SMR Code format as follows:

(a) The maintenance code entered in the third position will indicate the lowest maintenance level authorized to remove, replace, and use the support item. The maintenance code entered in the third position will indicate one of the following levels of maintenance.

<i>Code</i>	<i>Application/Explanation</i>
C	- Crew or operator maintenance performed within organizational maintenance.
O	- Support item is removed, replaced, used at the organizational level.
F	- Support item is removed, replaced, used at the direct support level.
H	- Support item is removed, replaced, used at the general support level.
D	- Support items that are removed, replaced, used at depot, mobile depot, or specialized repair activity only.

(b) The maintenance code entered in the fourth position indicates whether the item is to be repaired and identifies the lowest maintenance level with the capability to perform complete repair (i.e., all authorized maintenance functions). This position will contain one of the following maintenance codes.

<i>Code</i>	<i>Application/Explanation</i>
O	- The lowest maintenance level capable of complete repair of the support item is the organizational level.
F	- The lowest maintenance level capable of complete repair of the support item is the direct support level.
H	- The lowest maintenance level capable of complete repair of the support item is the general support level.
D	- The lowest maintenance level capable of complete repair of the support item is the depot level.
Z	- Nonreparable. No repair is authorized.
B	- No repair is authorized. The item may be reconditioned by adjusting, lubricating, etc., at the user level. No parts or special tools are procured for the maintenance of this item.

(3) *Recoverability Code.* Recoverability codes are assigned to support items to indicate the disposition action on unserviceable items. The recoverability code is entered in the fifth position of the Uniform SMR Code format as follows:

<i>Recoverability Codes</i>	<i>Definition</i>
Z	- Nonreparable item. When unserviceable, condemn and dispose at the level indicated in position 3.
O	- Repairable item. When uneconomically repairable, condemn and dispose at organizational level.
F	- Repairable item. When uneconomically repairable, condemn and dispose at the direct support level.

*Recoverability  
Codes*

*Definition*

- H - Repairable item. When uneconomically repairable, condemn and dispose at the general support level.
- D - Repairable item. When beyond lower level repair capability, return to depot. Condemnation and disposal not authorized below depot level.
- L - Repairable item. Repair, condemnation, and disposal not authorized below depot/specialized repair activity level.
- A - Item requires special handling or condemnation procedures because of specific reasons (i.e., precious metal content, high dollar value, critical material or hazardous material). Refer to appropriate manuals/directives for specific instructions.

c. *National Stock Number.* Indicates the National stock number assigned to the item and which will be used for requisitioning.

d. *Part Number.* Indicates the primary number used by the manufacturer (individual, company, firm, corporation, or Government activity), which controls the design and characteristics of the item by means of its engineering drawings, specifications, standards, and inspection requirements to identify an item or range of items.

**NOTE**

**When a stock numbered item is requisitioned, the item received may have a different part number than the part being replaced.**

e. *Federal Supply Code for Manufacturer (FSCM).* The FSCM is a 5-digit numeric code listed in SB 708-42 which is used to identify the manufacturer, distributor, or Government agency, etc.

f. *Description.* Indicates the Federal item name and, if required, a minimum description to identify the item. In the Special Tools List, the initial basis of issue (BOI) appears as the last line in the entry for each special tool, special TMDE, and other special support equipment. When density of equipments supported exceeds density spread indicated in the basis of issue, the total authorization is increased accordingly.

g. *Unit of Measure (U/M).* Indicates the standard of the basic quantity of the listed item as used in performing the actual maintenance function. This measure is expressed by a two-character alphabetical abbreviation (e.g., ea, in., pr, etc). When the unit of measure differs from the unit of issue, the lowest unit of issue that will satisfy the required units of measure will be requisitioned.

h. *Quantity Incorporated in Unit.* Indicates the quantity of the item used in the breakout shown on the illustration figure, which is prepared for a functional group, subfunctional group, or an assembly. A "V" appearing in this column in lieu of a quantity indicates that no specific quantity is applicable, (e.g., shims, spacers, etc).

**C-4. HOW TO LOCATE REPAIR PARTS**

a. *When National Stock Number or Part Number is Unknown:*

(1) First. Using the table of contents, determine the functional group within which the item belongs. This is necessary since illustrations are prepared for functional groups, and listings are divided into the same groups.

(2) Second. Find the illustration covering the functional group to which the item belongs.



(3) *Third.* Identify the item on the illustration and note the illustration figure and item number of the item.

(4) *Fourth.* Using the Repair Parts Listing, find the figure and item number noted on the illustration.

*b. When National Stock Number or Part Number is Known:*

(1) *First.* Using the Index of National Stock Numbers and Part Numbers, find the pertinent National stock number or part number. This index is in NIIN sequence followed by a list of part numbers in alphameric sequence, cross-referenced to the illustration figure number and item number.

(2) *Second.* After finding the figure and item number, locate the figure and item number in the repair parts list.

**C-5. ABBREVIATIONS**

<i>Abbreviations</i>	<i>Explanation</i>
ASSY	Assembly
CONN	Connecting
HEX	Hexagon
IDENT	Identification

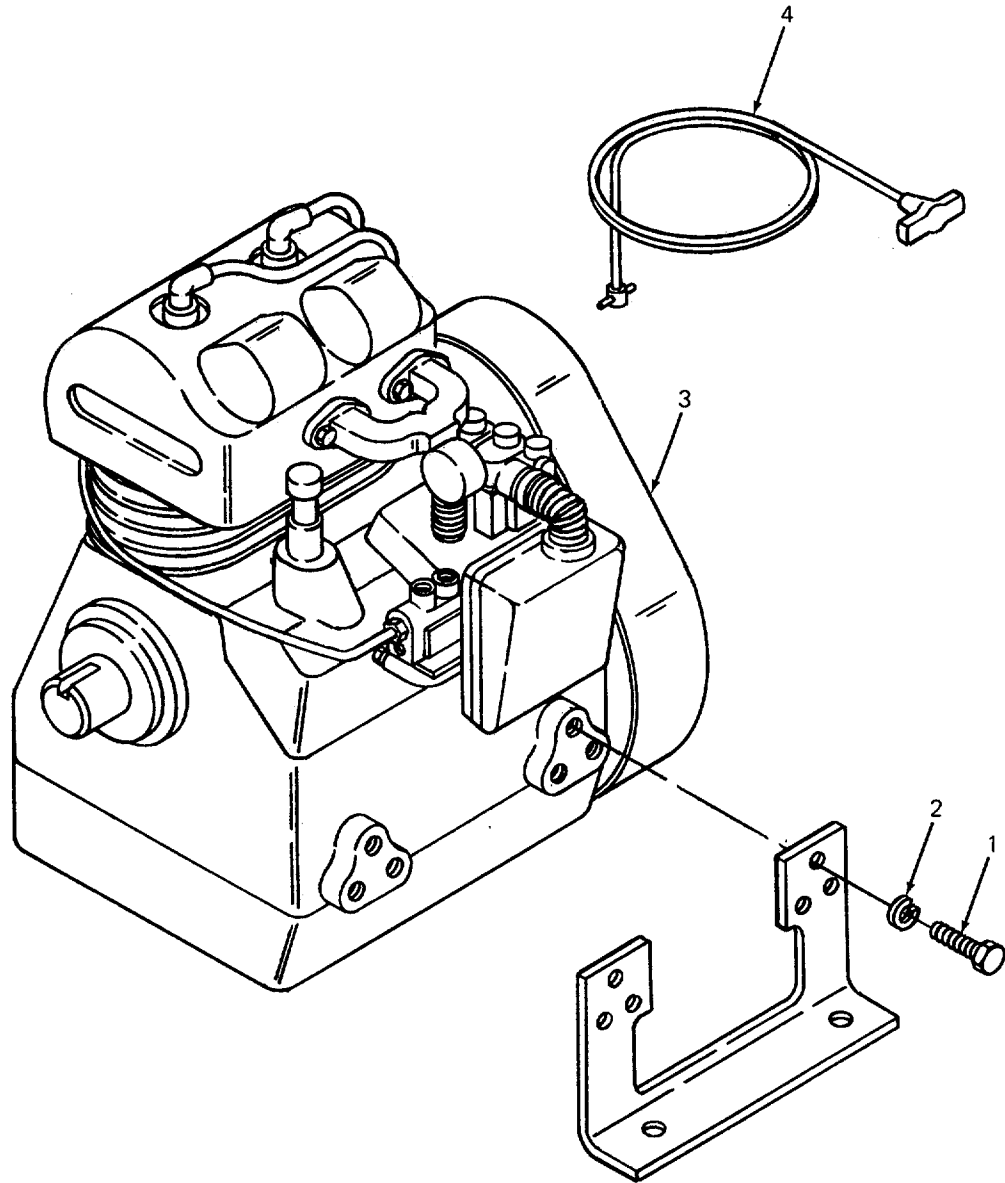

Figure 1. Engine Assembly.

(1) Illustration		(2)	(3)	(4)	(5)	(6) Description	(7)	(8) Qty Inc In Unit
(a) Fig No.	(b) Item No.	SMR Code	National Stock Number	FSCM	Part Number	Usable On Code	U/M	
						Section II. REPAIR PARTS LIST GROUP 01 ENGINE		
1	1	PAOZZ	5305-00-068-0502	96906	MS90725-6	SCREW, CAP, HEXAGON HEAD.....	EA	12
1	2	PAOZZ	5310-00-582-5965	96906	MS35338-44	WASHER, LOCK.....	EA	12
1	3	PAOFH	2805-01-169-1100	97403	2A016-4	ENGINE, GASOLINE (REFERENCE TM 5-2805-257-24P FOR PARTS BREAKDOWN).....	EA	1
1	4	PAOZZ	2990-00-972-7950	97403	9786E121	STARTER ROPE, ENGINE.....	EA	1

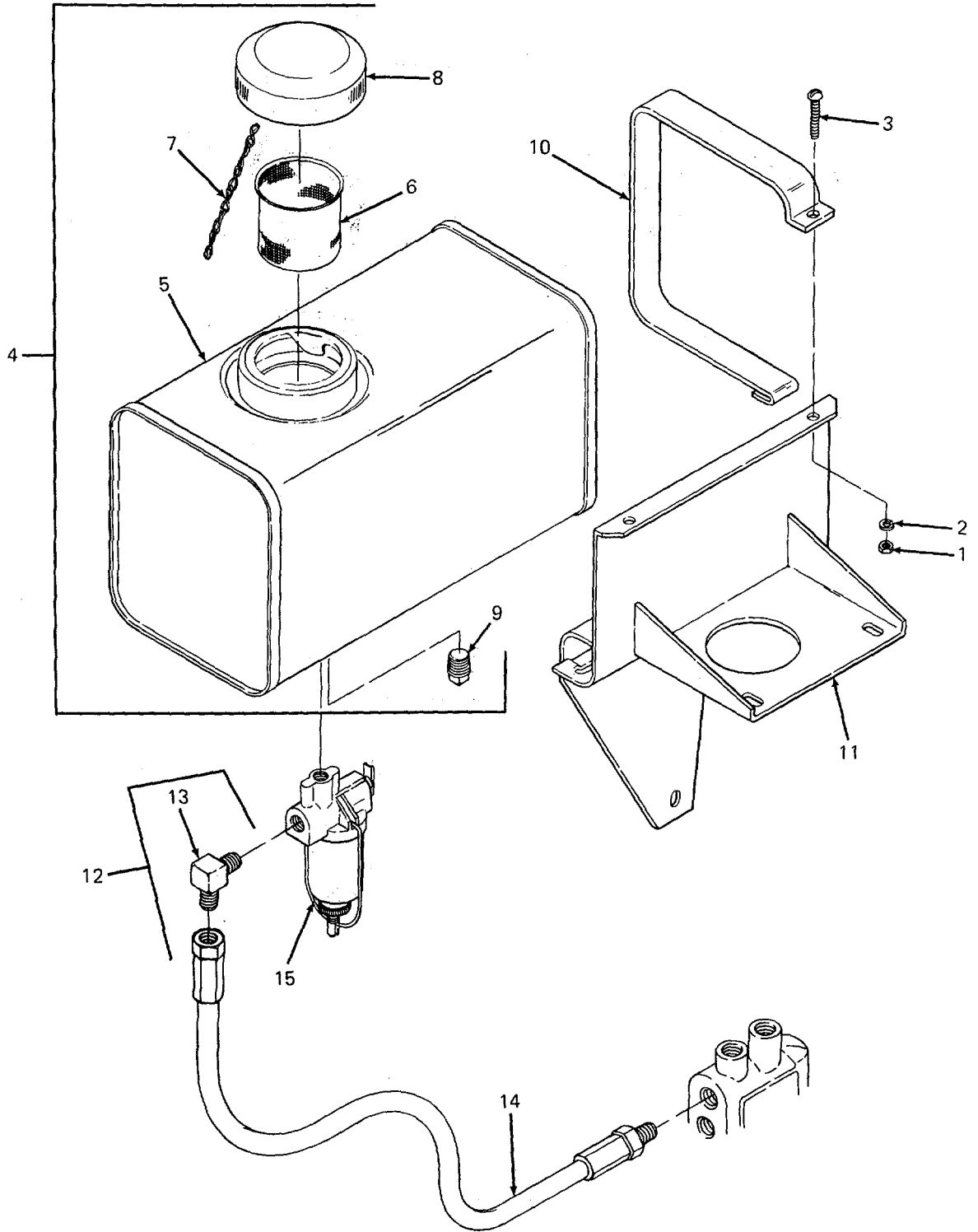

Figure 2. Tank, Line, Fittings, and Filter.

(1) Illustration		(2)	(3)	(4)	(5)	(6) Description	(7)	(8)
(a) Fig No.	(b) Item No.	SMR Code	National Stock Number	FSCM	Part Number	Usable On Code	U/M	Qty Inc In Unit
						GROUP 02 FULL SYSTEM		
2	1	PAOZZ	5310-01-012-7400	05748	15361	NUT, PLAIN. HEXAGON .....	EA	1
2	2	PAOZZ	5310-00-045-3296	96906	MS35338-43	WASHER. LOCK .....	EA	2
2	3	PAOZZ	5305-00-068-1802	96906	MS35218-59	SCREW. MACHINE .....	EA	2
2	4	PADZH	2910-00-707-7502	97403	1320E8821	TANK. FUEL. ENGINE .....	EA	1
2	5	XAOZZ		05748	18326	BODY. FUEL TANK.....	EA	1
2	6	PAOZZ	2910-00-697-1384	05748	18327	.STRAINER ELEMENT SEDIMENT .....	EA	1
2	7	XBOZZ		05748	18328	.CHAIN, CAP. NO.18 STEEL, SINGLE JACK. APPROX 3.75 IN. LG.	EA	1
2	8	PAOZZ	2910-00-605-1353	29510	193421H1	.CAP. FILLER OPENING .....	EA	1
2	9	PAOZZ	4730-00-163-4680	05748	03200	.PLUG. PIPE .....	EA	1
2	10	PAOZZ		97403	13200E8823	STRAP, FUEL TANK.....	EA	1
2	11	XBOZZ		05748	18310SA	BRACKET. FUEL TANK.....	EA	1
2	12	XBOOO		05748	35481SA	FUEL LINE ASSEMBLY.....	EA	1
2	13	PAOZZ	4730-00-810-0059	05748	35564	.ELBOW, PIPE.....	EA	1
2	14	PAOZZ	4720-00-904-6608	05748	24959	.HOSE ASSEMBLY, NONMETALLIC.....	EA	1
2	15	PAOZZ	2910-00-905-9792	96906	MS51086-1	STRAINER, SEDIMENT .....	EA	1

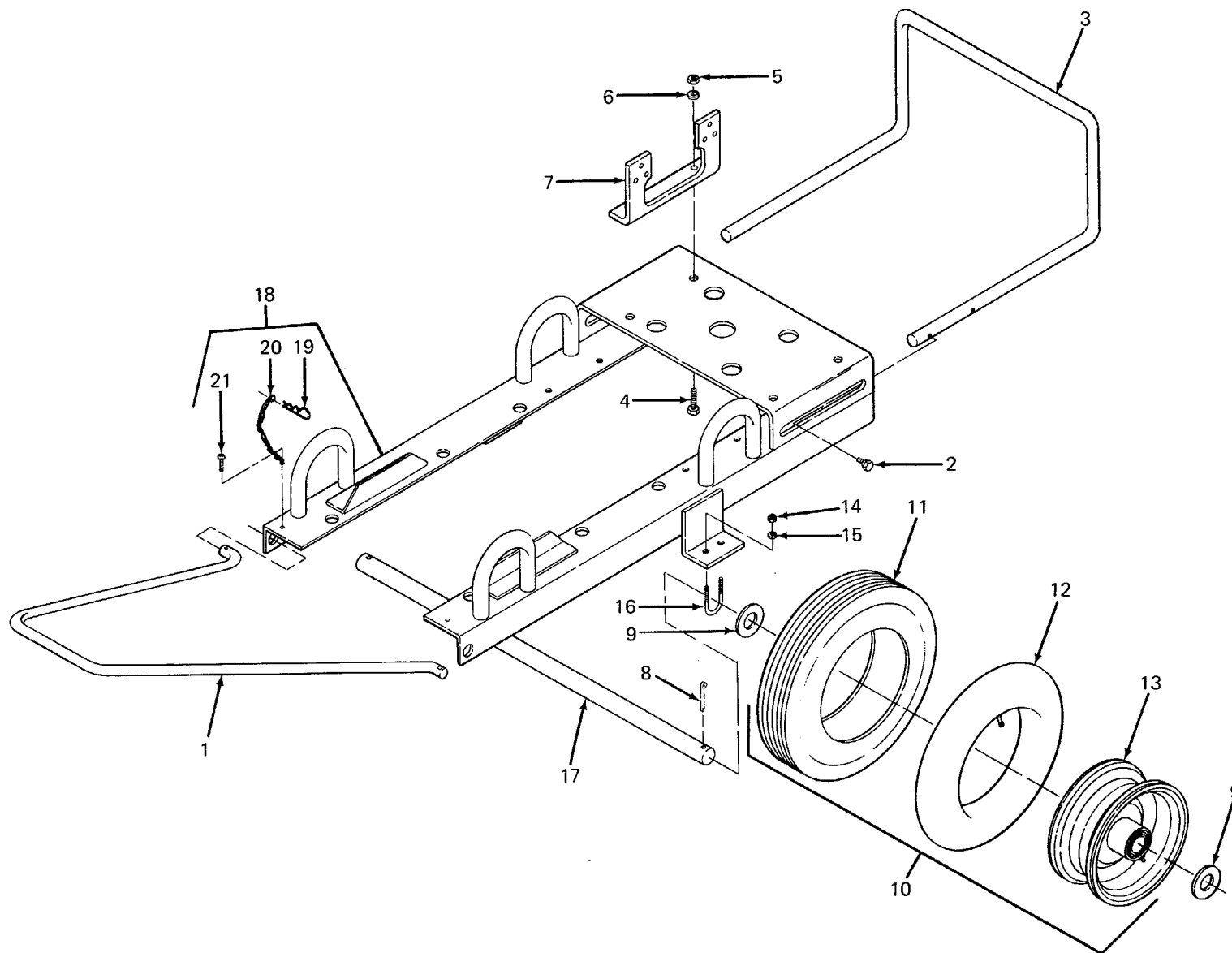
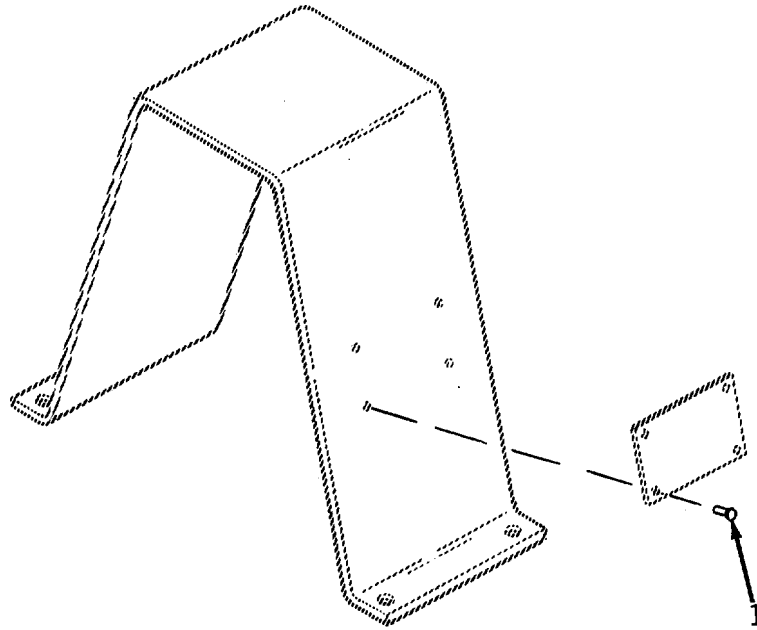

Figure 3. Frame Assembly and Wheels.

(1) Illustration		(2)	(3)	(4)	(5)	(6) Description	(7)	(8)
(a) Fig No.	(b) Item No.	SMR Code	National Stock Number	FSCM	Part Number	Usable On Code	U/M	Qty Inc In Unit
3	1	PBOZZ	3920-01-128-4664	05748	70047	GROUP 03 FRAME DRAW, BAR .....	EA	1
3	2	PAOZZ	5306-01-132-5599	05748	70554	BOLT, SHOULDER .....	EA	4
3	3	PBOZZ	4320-01-132-4909	05748	70050	GUARD, ENGINE .....	EA	1
3	4	PAOZZ	5305-00-269-3211	96906	MS90725-60	SCREW, CAP, HEXAGON HEAD.....	EA	4
3	5	PAOZZ	5310-00-732-0558	96906	MS51967-8	NUT, PLAIN, HEXAGON .....	EA	4
3	6	PAOZZ	5310-00-637-9541	96906	MS35338-46	WASHER LOCK .....	EA	4
3	7	XBOZZ		05748	70020	BRACKET ENGINE .....	EA	2
3	8	PAOZZ	5315-00-849-9854	96906	MS24665-498	PIN, COTTER .....	EA	2
3	9	PAOZZ	5310-00-543-2500	96906	MS15795-826	WASHER, FLAT .....	EA	4
3	10	XDOOO	2530-01-132-7493	11431	52349551	WHEEL & TIRE. ASSEMBLY.....	EA	2
3	11	PBOZZ		11431	9551	.TIRE .....	EA	2
3	12	PAOOO		11431	9474	.TUBE, INNER .....	EA	1
3	13	XDOZZ		11431	5234	.WHEEL .....	EA	2
3	14	PAOZZ	5310-00-761-6882	96906	MS51967-2	NUT, PLAIN, HEXAGON .....	EA	4
3	15	PAOZZ	5310-00-582-5965	96906	MS35338-44	WASHER, LOCK .....	EA	4
3	16	PAOZZ	5306-01-132-0503	05748	62272	U-BOLT .....	EA	2
3	17	PBOZZ	4320-01-130-1285	05748	70039	AXLE PUMP.....	EA	1
3	18	XBOFF		05748	70027SA	BASE ASSEMBLY.....	EA	1
3	19	PAOZZ		05748	70048	.PIN, HITCH.....	EA	2
3	20	XBOZZ		05748	387317	.CHAIN NO.16 STEEL, SINGLE JACK, APPROX 4 IN LG.....	EA	2
3	21	PAOZZ	5305-00-052-5054	96906	MS24630-35	.SCREW, TAPPING THREAD .....	EA	2



70004		<b>US</b>	
PUMP, RECIPROCATING, POWER - DRIVEN DIAPHRAGM GED, CLASS 2, 4 INCH			
MODEL US40CDG	CONTR NR DAAJ09-79-C-5192		
SER NR 70046-XAX	CAPACITY 100 GPM		
REG NR	GVW	LB	LG 41 IN
NSN 4320-01-092-2210	DATE MFD	XCX	HGT 32 IN
ENG SER XBX	SHIP WT	560 LB	W 34 IN
WARRANTY	MO	MI	CU 26 FT
DATE SHIPPED	XCX	DATE INSP	INSP STAMP
<b>BARNES PUMP</b> MFD BY PEABODY BARNES INC. MANSFIELD OHIO USA			

↑  
2

70005	OPERATING PROCEDURE
<ol style="list-style-type: none"> <li>1. CHECK ENGINE OIL LEVEL - IF LOW FILL TO REQUIRED LEVEL WITH OIL TO MIL - L - 2104.</li> <li>2. CHECK GEAR BOX OIL LEVEL - IF LOW FILL TO REQUIRED LEVEL WITH SAE 90.</li> <li>3. APPLY GREASE TO ZERK FITTING AND CONNECTING ROD BEARING WITH GREASE TO MIL - G - 23827.</li> </ol>	
(A) TIE DOWN SLINGING PROVISIONS, (MULTI-EYES).	

↑  
3

Figure 4. Data Plates.



(1) Illustration		(2)	(3)	(4)	(5)	(6) Description	(7)	(8) Qty Inc In Unit	
(a) Fig No.	(b) Item No.	SMR Code	National Stock Number	FSCM	Part Number	Usable On Code	U/M		
4	1	PAOZZ	5320-01-023-2529	81349	M24243/1-A404	GROUP 04 ACCESSORY ITEMS			
4	2	XDOZZ		05748		51454	RIVET, BLIND.....	EA	4
4	3	XDOZZ		05748		70005	PLATE, ID..... PLATE, OPERATING INSTRUCTIONS.....	EA EA	1 1

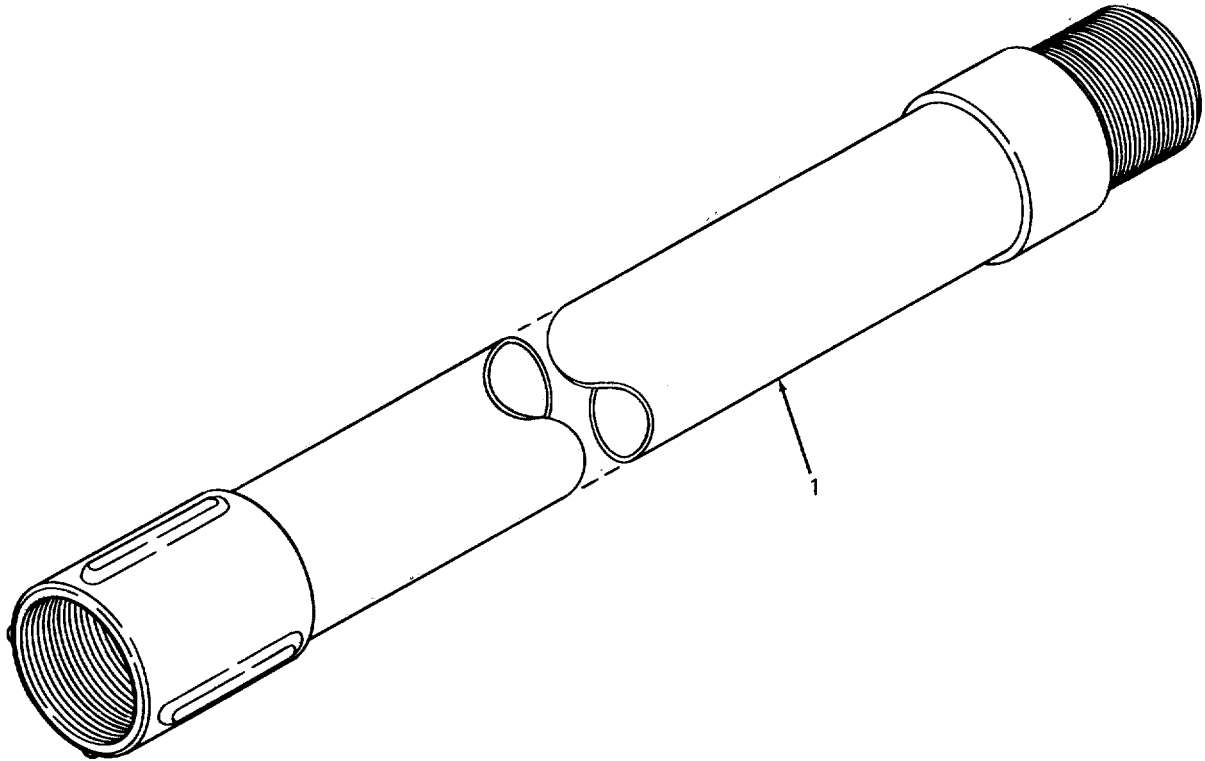

Figure 5. Suction Hose.

(1) Illustration		(2)	(3)	(4)	(5)	(6) Description	(7)	(8) Qty Inc In Unit
(a) Fig No.	(b) Item No.	SMR Code	National Stock Number	FSCM	Part Number	Usable On Code	U/M	
5	1	PAOZO	4720-00-202-8653	05748	70559	HOSE ASSEMBLY, NONMETALLIC.....	EA	4
5	2	PAOZZ	4730-00-203-6309	21363	D1345D	STRAINER.....	EA	1

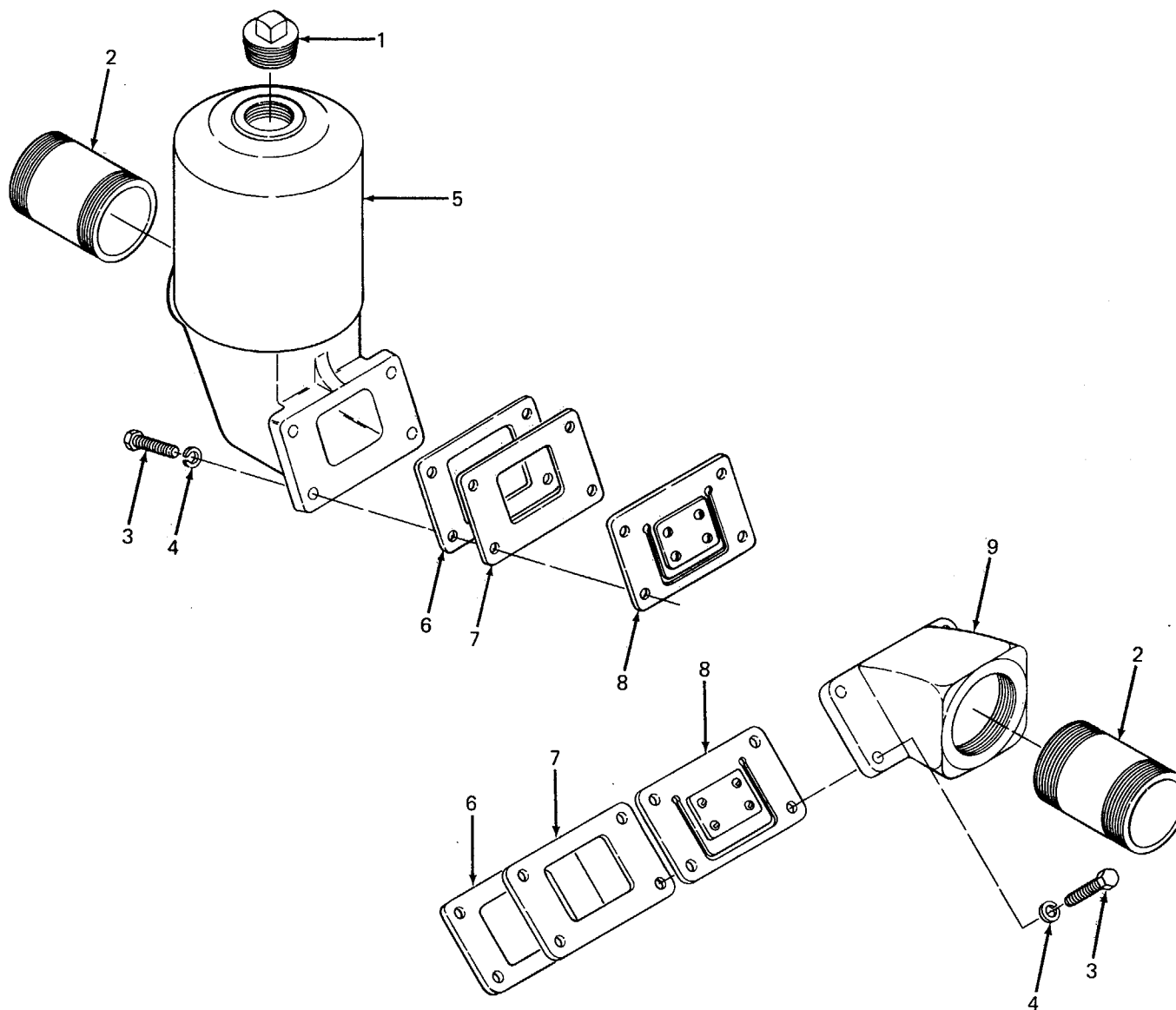

Figure 6. Accumulator, Check Valve Assemblies, and Discharge Port.

(1) Illustration		(2)	(3)	(4)	(5)	(6) Description	(7)	(8) Qty Inc In Unit
(a) Fig No.	(b) Item No.	SMR Code	National Stock Number	FSCM	Part Number	Usable On Code	U/M	
						GROUP 05 PUMP		
6	1	PAOZZ	4730-00-826-6516	96906	MS51884-17ZH	PLUG, PIPE.....	EA	1
6	2	PAOZZ	4730-00-196-1562	96906	MS51953-270	NIPPLE, PIPE.....	EA	2
6	3	PAOZZ	5305-00-042-6417	96906	MS90725-113	SCREW, CAP, HEXAGON HEAD.....	EA	8
6	4	PAOZZ	5310-00-584-5272	96906	MS35338-48	WASHER, LOCK.....	EA	8
6	5	XBOFF		05748	70040	ACCUMULATOR.....	EA	1
6	6	PAOZZ	5330-01-132-2205	05748	70015	GASKET.....	EA	2
6	7	PAOZZ		05748	70014	PLATE, SEAL.....	EA	2
6	8	PAOZZ	4820-01-130-1300	05748	70044SA	VALVE, CHECK.....	EA	2
6	9	XBOFF		05748	70041	PORT DISCHARGE.....	EA	1

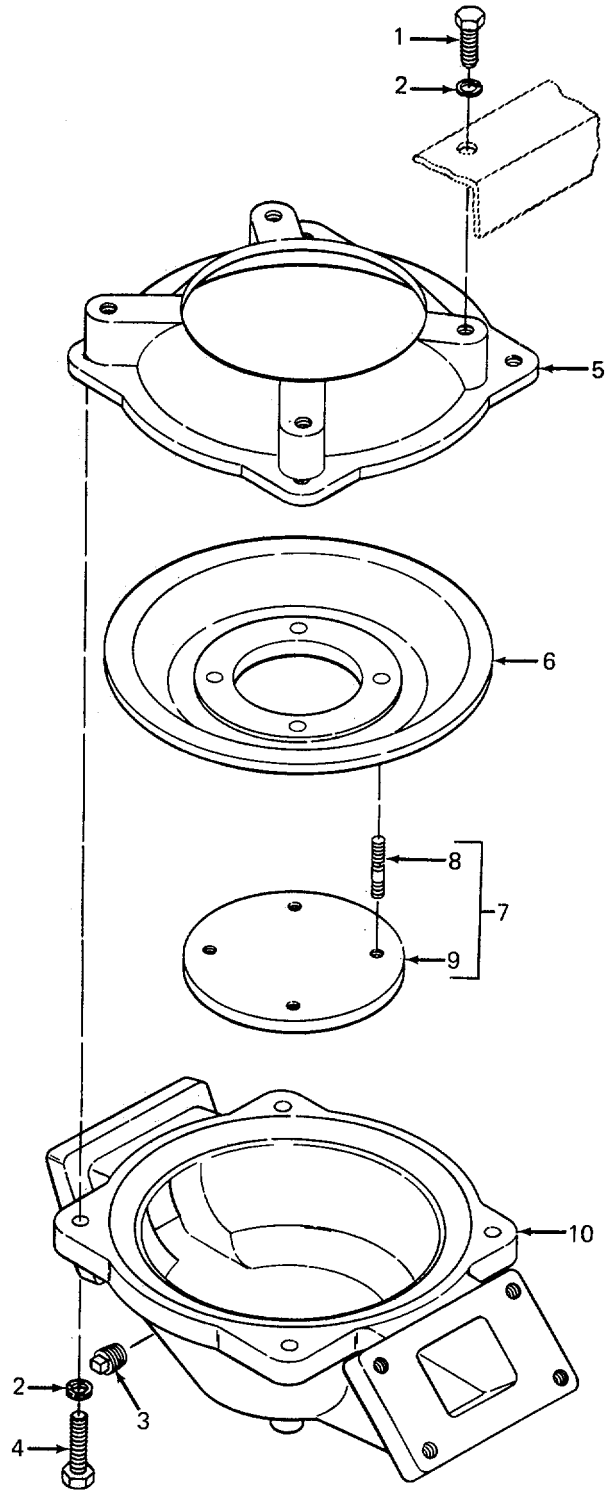

Figure 7. Diaphragm

(1) Illustration		(2)	(3)	(4)	(5)	(6) Description	(7)	(8) Qty Inc In Unit
(a) Fig No.	(b) Item No.	SMR Code	National Stock Number	FSCM	Part Number	Usable On Code	U/M	
7	1	PAOZZ	5305-00-724-5910	96906	MS90725-162	SCREW,CAP,HEXAGON HEAD .....	EA	2
7	2	PAOZZ	5310-00-820-6653	80045	23MS35338-50	WASHER,LOCK .....	EA	6
7	3	PAOZZ	4730-00-044-4587	96906	MS51884-7	PLUG,PIPE .....	EA	1
7	4	PAOZZ	5305-00-724-5913	96906	MS90725-166	SCREW,CAP,HEXAGON, HEAD.....	EA	4
7	5	XBOFF		05748	70002	CLAMP.....	EA	1
7	6	PAOZZ		05748	00129	DIAPHRAGM .....	EA	1
7	7	PBOOZ	4320-01-130-6295	05748	700455A	CLAMP ASSEMBLY.....	EA	1
7	8	PADZZ		05748	70038	STUD,PLAIN.....	EA	4
7	9	XAOFF		05748	70017	CLAMP,CONNECTING ROD .....	EA	1
7	10	XBOFF		05748	70001	BOWL .....	EA	1

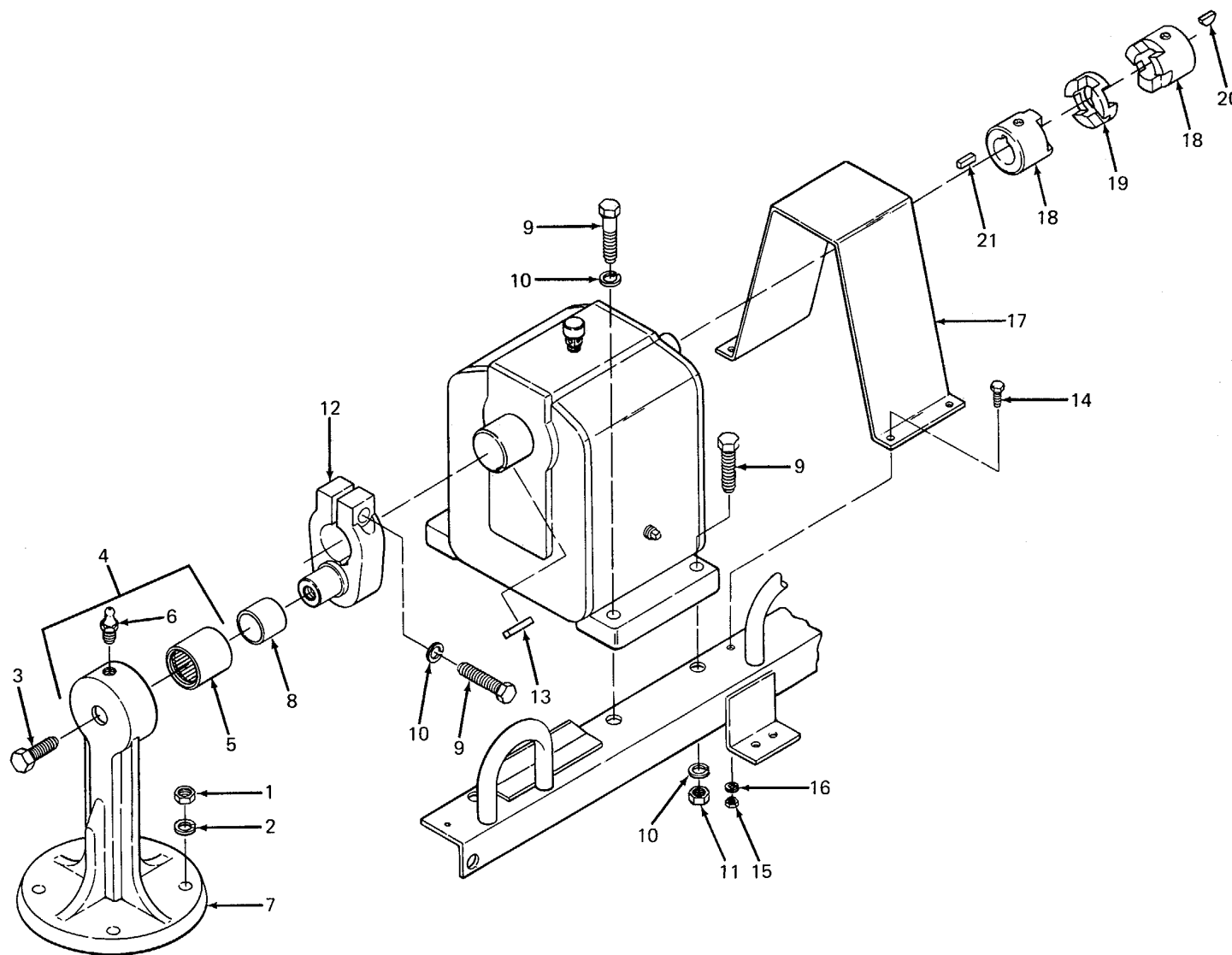

Figure 8. Connecting Rod Assembly.



(1) Illustration		(2)	(3)	(4)	(5)	(6) Description	(7)	(8)
(a) Fig No.	(b) Item No.	SMR Code	National Stock Number	FSCM	Part Number	Usable On Code	U/M	Qty Inc In Unit
8	1	PAOZZ	5310-00-768-0318	96906	MS51967-14	NUT, PLAIN, HEXAGON.....	EA	4
8	2	PAOZZ	5310-00-584-5272	96906	MS35338-48	WASHER, LOCK .....	EA	4
8	3	PAOZZ	5306-01-132-0498	05748	70019	BOLT,CRANK.....	EA	1
8	4	XBOFF		05748	70043SA	ROD ASSEMBLY, CONNECTING .....	EA	1
8	5	PAOZZ	3110-00-227-3249	96906	MS51961-22	BEARING,ROLLER.NEEDLE.....	EA	1
8	6	PAOZZ	4730-00-048-1788	95879	16278	FITTING, LUBRICATION .....	EA	1
8	7	XBOZZ		05748	70016	ROD, CONNECTING .....	EA	1
8	8	PAOZZ	3110-00-198-1389	96906	MS51962-22	RING, BEARING, INNER.....	EA	1
8	9	PAOZZ	5305-00-724-5913	56906	MS90725-166	SCREW, CAP, HEXAGON HEAD.....	EA	5
8	10	PAOZZ	5310-00-820-6653	80045	23MS35338-50	WASHER, LOCK .....	EA	5
8	11	PAOZZ	5310-00-763-8920	96906	MS51967-20	NUT, PLAIN, HEXAGON.....	EA	2
8	12	XDOZZ		05748	70018	CRANK .....	EA	1
8	13	PAOZZ	5315-01-132-3562	05748	37165	KEY,SQUARE.....	EA	1
8	14	PAOZZ	5305-00-068-0502	96906	MS90725-6	SCREW, CAP,HEXAGON HEAD.....	EA	4
8	15	PAOZZ	5310-00-761-6882	96906	MS51967-2	NUT,PLAIN,HEXAGON .....	EA	4
8	16	PAOZZ	5310-00-582-5965	96906	MS35338-44	WASHER, LOCK.....	EA	4
8	17	XBOZZ		05748	70049	GUARD, COUPLING .....	EA	1
8	18	PAOZZ	3010-00-517-1848	75065	L100-1-250BORE	COUPLING, SHAFT, FLEX .....	EA	1
8	19	PAOZZ		75665	1X406	INSERT,FLEX COUPLING.....	EA	1
8	20	PAOZZ	5315-00-043-1787	96906	MS35756-34	KEY WOODRUFF, .....	EA	1
8	21	PAOZZ	5315-01-130-7863	05748	39328	KEY,SQUARE.....	EA	

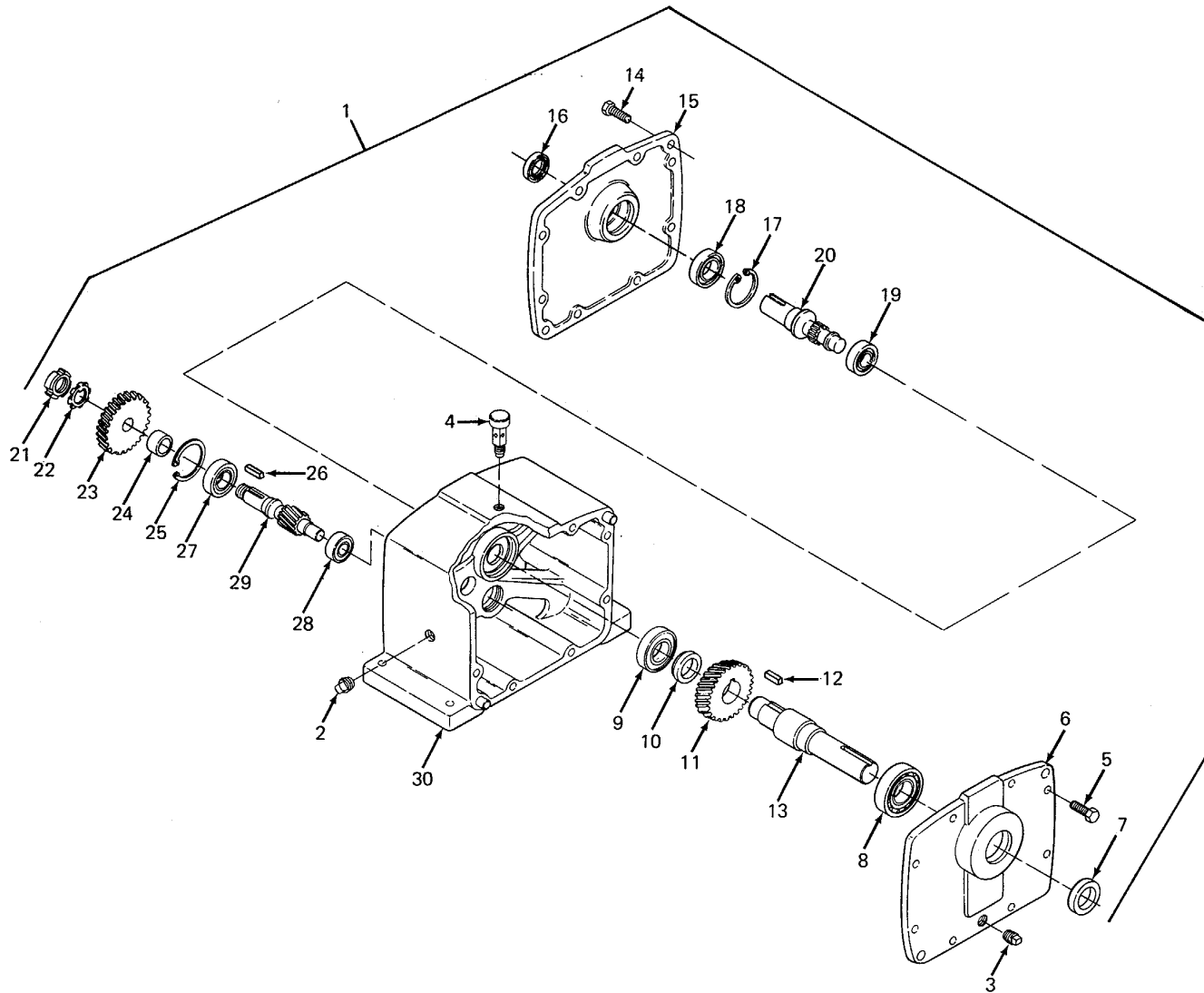

Figure 9. Gear Reducer

(1) Illustration		(2)	(3)	(4)	(5)	(6) Description	(7)	(8)
(a) Fig No.	(b) Item No.	SMR Code	National Stock Number	FSCM	Part Number	Usable On Code	U/M	Qty Inc In Unit
9	1	PAOFF	3010-01-131-3639	61147	7ND549YU1UA 02N01	REDUCER ASSY, GEAR .....	EA	1
9	2	XDOZZ		61147	A688003AA013	.PLUG, PIPE, LEVEL .....	EA	1
9	3	XDOZZ		61147	A688003AA012	.PLUG, PIPE, DRAIN .....	EA	1
9	4	XDOZZ		61147	A697002AG701	.BREATHER .....	EA	1
9	5	XDOZZ	5305-01-133-0653	61147	A684001AC310	.BOLT .....	EA	8
9	6	XDOZZ		61147	B615174AA001	.COVER, OUTPUT .....	EA	1
9	7	PAFZZ	5330-01-129-9471	61147	A676000AH354	.SEAL, OUTPUT .....	EA	1
9	8	PAFZZ		61147	A673023AA027	.BEARING, ROLLER .....	EA	1
9	9	PAFZZ		61147	A673023AA028	.BEARING, ROLLER .....	EA	1
9	10	XDFZZ	5315-01-133-0654	61147	A670006AA007	.KEY, SQUARE .....	EA	1
9	11	PBFZZ	3020-01-129-3031	61147	A621009AB001	.GEAR, LOW-SPEED .....	EA	1
9	12	XDFZZ	5315-01-133-0656	61147	A671001AA006	.KEY .....	EA	1
9	13	PBFZZ	3040-01-130-1713	61147	B630052AG002	.SHAFT, OUTPUT .....	EA	1
9	14	XDOZZ		61147	B615190AA001	.COVER, INPUT .....	EA	1
9	15	PAFZZ	5330-01-129-9472	61147	A676000AE207	.SEAL, INPUT .....	EA	1
9	16	PAFZZ	5365-01-132-0815	61147	A685001AB137	.RING, SNAP .....	EA	1
9	17	PAFZZ		61147	A673003AA207	.BEARING, ROLLER .....	EA	1
9	18	PAFZZ		61147	A673002AA303	.BEARING, ROLLER .....	EA	1
9	19	PBFZZ	3040-01-130-2124	61147	B632042AG001	.SHAFT, INPUT .....	EA	1
9	20	PAFZZ	5310-01-130-1149	61147	A684016AA106	.LOCKNUT .....	EA	1
9	21	PAFZZ	5310-01-133-0961	61147	A685011AA106	.WASHER, LOCK .....	EA	1
9	22	PBFZZ	3020-01-131-3640	61147	A620009AS	.GEAR, HIGH-SPEED .....	EA	1
9	23	PAFZZ	5365-01-130-1196	61147	A660003A0019	.SPACER, SLEEVE .....	EA	1
9	24	PAFZZ	5365-01-132-1928	61147	A685000AB283	.RING, SNAP .....	EA	1
9	25	XDFZZ		61147	A670003AA010	.KEY, SQUARE .....	EA	1
9	26	PAFZZ		61147	A673003AA207	.BEARING, ROLLER .....	EA	1
9	27	PAFZZ		61147	A673024A0017	.BEARING, ROLLER .....	EA	1
9	28	PBFZZ	4320-01-130-4071	61147	B694010AB701	.JACKSHAFT .....	EA	1
9	29	XDFZZ		61147	C600054AA001	.HOUSING, GEAR .....	EA	1

(1) Illustration		(2)	(3)	(4)	(5)	(6) Description	(7)	(8) Qty Inc In Unit
(a) Fig No.	(b) Item No.	SMR Code	National Stock Number	FSCM	Part Number	Usable On Code	U/M	
9	27	PAFZZ	4320-01-130-4071	50706	7ND549YU1UA01N01-127	.BEARING.ROLLER.....	EA	1
9	28	PAFZZ		50706	7ND549YU1UA01N01-126	.BEARING.ROLLER.....	EA	1
9	29	PBFZZ		50706	7N549YU1UA01N01-230	.JACK,SHAFT INSTALL NEW LOW-SPEED GEAR -235 WHEN NEW..... .JACK,SHAFT IS INSTALLED.....	EA	1
9	30	XAFZZ		50706	7ND549YU1UA01N01-001	.HOUSING.GEAR.....	EA	1

SECTION IV. NATIONAL STOCK NUMBER AND PART NUMBER INDEX

STOCK NUMBER	FIGURE NO.	ITEM NO.
5305-00-042-6417	6	3
5315-00-043-1787	8	20
4730-00-044-4587	7	3
5310-00-045-3296	2	2
4730-00-048-1788	8	6
5305-00-052-9050	3	21
5305-00-068-0502	1	1
5305-00-068-0502	8	14
5305-00-068-1802	2	3
4730-00-163-4680	2	9
4730-00-196-1562	6	2
3110-00-198-1389	8	8
4720-00-202-8653	5	1
4730-00-203-6309	5	2
3110-00-227-3249	8	5
5305-00-269-3211	3	4
3010-00-517-1848	8	18
5310-00-543-2500	3	9
5310-00-582-5965	1	2
5310-00-582-5965	3	15
5310-00-582-5965	8	16
5310-00-584-5272	6	4
5310-00-584-5272	8	2
2910-00-605-1353	2	8
5310-00-637-9541	3	6
2910-00-697-1384	2	6
2910-00-707-7502	2	4
5305-00-724-5910	7	1
5305-00-724-5913	7	4
5305-00-724-5913	8	5
5310-00-732-0558	3	5
5310-00-761-6882	3	14
5310-00-761-6882	8	15
5310-00-763-8920	8	11
5310-00-768-0318	8	1
4730-00-810-0059	2	13
5310-00-820-6653	7	2
5310-00-820-6653	8	10

STOCK NUMBER	FIGURE NO.	ITEM NO.
4730-00-826-6516	6	1
5315-00-849-9854	3	8
4720-00-904-6608	2	14
2910-00-905-9792	2	15
2990-00-972-7950	1	4
5310-01-012-7400	2	1
5320-01-023-2529	4	1
3920-01-128-4664	3	1
3020-01-129-3031	9	11
5330-01-129-9471	9	7
5330-01-129-9472	9	15
5310-01-130-1149	9	20
5365-01-130-1196	9	23
4320-01-130-1285	3	17
4820-01-130-1300	6	8
3040-01-130-1713	9	13
3040-01-130-2124	9	19
4320-01-130-4071	2	8
4320-01-130-6295	7	7
5315-01-130-7863	8	21
3010-01-131-3639	9	1
3020-01-131-3640	9	22
5306-01-132-0498	8	3
5306-01-132-0503	3	16
5365-01-132-0815	9	16
5365-01-132-1928	9	24
5330-01-132-2205	6	6
5315-01-132-3562	8	13
4320-01-132-4909	3	3
5306-01-132-5599	3	2
2530-01-132-7493	3	10
5305-01-133-0653	9	5
5315-01-133-0654	9	10
5315-01-133-0656	9	12
5310-01-133-0961	9	21
2805-01-169-1100	1	3

FSCM	PART NUMBER	FIGURE NO.	ITEM NO.
61147	A620009AS	9	22
61147	A621009AB001	9	11
61147	A660003AA0019	9	23
61147	A670003AA010	9	25
61147	A670006AA007	9	10
61147	A671001AA006	9	12
61147	A673002AA303	9	18
61147	A673003AA207	9	17
61147	A673003AA207	9	26
61147	A673023AA027	9	8
61147	A673023AA028	9	9
61147	A673024A0017	9	27
61147	A676000AE207	9	15
61147	A676000AH354	9	7
61147	A684001AC310	9	5
61147	A684016AA106	9	20
61147	A685000AB283	9	24
61147	A685001AB137	9	16
61147	A685011AA106	9	21
61147	A688003AA012	9	3
61147	A688003AA013	9	2
61147	A697002AG701	9	4
61147	B615174AA001	9	6
61147	B615190AA001	9	14
61147	B630052AG002	9	13
61147	B632042AG001	9	19
61147	B694010AB701	9	28
61147	C600054AA001	9	29
75665	L100-1-250BORE	8	18
96906	MS15795-826	3	9
96906	MS24630-35	3	21
96906	MS24665-498	3	8
96906	MS35218-59	2	3
96906	MS35338-43	2	2
96906	MS35338-44	1	2
96906	MS35338-44	3	15
96906	MS35338-44	8	16
96906	MS35338-46	3	6
96906	MS35338-48	6	4
96906	MS35338-48	8	2
96906	MS35756-34	8	20
96906	MS51086-1	2	15
96906	MS51884-17ZH	6	1
96906	MS51884-7	7	3

FSCM	PART NUMBER	FIGURE NO.	ITEM NO.
96906	MS51961-22	8	5
96906	MS51962-22	8	8
96906	MS51967-14	8	1
96906	MS51967-2	3	14
96906	MS51967-2	8	15
96906	MS51967-20	8	11
96906	MS51967-8	3	5
96906	MS90725-113	6	3
96906	MS90725-162	7	1
96906	MS90725-166	7	4
96906	MS90725-166	8	9
96906	MS90725-6	1	1
96906	MS90725-6	8	14
96906	MS90725-60	3	4
81349	MS24243/1-A404	4	1
05748	00129	7	6
05748	03200	2	9
75665	1X406	8	19
97403	13200E8821	2	4
97403	13200E8823	2	10
05748	15361	2	1
95879	1627B	8	6
05748	18310SA	2	11
05748	18326	2	5
05748	18327	2	6
05748	18328	2	7
29510	193421H1	2	8
97403	2A016-4	1	3
80045	23MS35338-50	7	2
80045	23MS35338-50	8	10
05748	24959	2	14
05748	35481SA	2	12
05748	35564	2	13
05748	37165	8	13
05748	38737	3	20
05748	39328	8	21
05748	51454	4	2
96906	MS51953-270	6	2
11431	5234	3	13
11431	52349551	3	10
05748	62272	3	16
61147	7ND549YU1UA02N0.1	9	1

NATIONAL STOCK NUMBER AND PART NUMBER INDEX

SECTION IV

FSCM	PART NUMBER	FIGURE NO.	ITEM NO.	FSCM	PART NUMBER	FIGURE NO.	ITEM NO.
05748	70001	7	10	05748	70040	6	5
05748	70002	7	5	05748	70041	6	9
				05748	70043SA	8	4
05748	70005	4	3	05748	70044SA	6	8
05748	70014	6	7	05748	70045SA	7	7
05748	70015	6	6	05748	70047	8	1
05748	70016	8	7	05748	70048	8	19
05748	70017	7	9	05748	70049	8	17
05748	70018	8	12	05748	70050	3	3
05748	70019	8	3	05748	70554	3	2
05748	70020	3	7	05748	70559	5	1
05748	70027SA	3	18	11431	9474	3	12
05748	70038	7	8	11431	9551	3	11
05748	70039	3	17	97403	9786E121	1	4

**APPENDIX D  
EXPENDABLE SUPPLIES AND MATERIALS LIST**

---

**Section I. INTRODUCTION**

**D-1. SCOPE**

This appendix lists expendable supplies and materials you will need to operate and maintain the US40CDG Pump. These items are authorized to you by CTA 50-970, Expendable items (Except Medical, Class V, Repair Parts, and Heraldic Items).

**D-2. EXPLANATION OF COLUMNS**

- a. *Column 1 Item number.* This number is assigned to the entry in the listing and is referenced in the narrative instructions to identify the material (e.g., "Use cleaning compound, item 5, App. D").
- b. *Column 2 Level.* This column identifies the lowest level of maintenance that requires the listed item.  
  
O- Organizational Maintenance  
F- Direct Support Maintenance
- c. *Column 3 National Stock Number.* This is the National stock number assigned to the item; use it to request or requisition the item.
- d. *Column 4 Description.* Indicates the Federal item name and, if required, a description to identify the item. The last line for each item indicates the part number followed by the Federal Supply Code for Manufacturer (FSCM) in parentheses, if applicable.
- e. *Column 5 Unit of Measure (U/M).* Indicates the measure used in performing the actual maintenance function. This measure is expressed by a two-character alphabetical abbreviation (e.g., ea, in., pr). If the unit of measure differs from the unit of issue, requisition the lowest unit of issue that will satisfy your requirements.

Section II. EXPENDABLE SUPPLIES AND MATERIALS LIST

(1) Item Number	(2) Level	(3) National Stock Number	(4) Description	(5) U/M
1	O		LUBRICATING OIL, INTERNAL COM- BUSTION ENGINE, HEAVY DUTY, MIL-L-2104, GRADE 10 OR GRADE 30	
2	O, F		DRY CLEANING SOLVENT, P-D-680	
3	O		GREASE, INSTRUMENT, AIRCRAFT, MIL-G-23827	
4	O		GREASE, AUTOMOTIVE AND ARTIL- LERY, MIL-G-10924	
5	O, F		LUBRICATING OIL, GEAR, MULTI- PURPOSE, .MIL-M-2105, GRADE 90	
6	O, F		GREASE, BALL AND ROLLER BEARING, MIL-G-18709	
7	O, F		LOCTITE NO. 242 (05972)	
8	F		SEALER, SILMATE NO. A689005AA-006 (02787)	



GLOSSARY

**Section I. ABBREVIATIONS**

amps .....	Ampere
°C .....	Degree Celsius
CBR .....	Chemical-biological-radiological
EIR .....	Equipment Improvement Recommendations
° F .....	Degree Fahrenheit
ft lb .....	Foot pound
gpm .....	Gallons per minute
kg.....	Kilogram
kPa .....	Kilopascal
lb.....	Pound
mm .....	Millimeter
MTOE .....	Modified table of organization and equipment
N•m .....	Newton-meter
NPT .....	National pipe thread
phr .....	Pounds per hour
PMCS .....	Preventive maintenance checks and services
psi.....	Pounds per square inch
rpm .....	Revolutions per minute
TMDE .....	Test, measurement, and diagnostic equipment
vdc.....	Volts direct current

**Section II. DEFINITION OF UNUSUAL TERMS**

**A**

**ABRASION** - A scraped or scuffed area. A hose may become abraded if an unshielded portion of it rubs against a piece of bracket or another hose.

**ALIGN** - To arrange in a line vertically and/or horizontally. In order to bolt check valve assembly to pump bowl, bolt holes must be aligned.

**ALLOCATION** - Assignment of duties or materials according to a plan.

**ALPHA-NUMERIC** - In alphabetical and numerical order. An alpha-numeric die set includes one die for each letter in the alphabet, and one die for each number zero through nine.

**APPENDIX** - A collection of supplementary material at the end of a book.

**APPROVED** - Permitted to be used for a specific purpose by the person or group who is allowed to grant approval.

**ASSEMBLY** - A combination of parts that may be taken apart without destruction, which has no application or use of its own but is needed for the completeness of a more complex item with which it is combined, or to which it is attached.

**B**

**BAIL** - An arched, hooplike handle, as of a pail.

**BRINELLED** - A deformation of a bearing by an impact.

**C**

**CAPACITY** - The volume, amount, or quantity that can be held or contained. The fluid capacity of the hydraulic system is 2.5 gallons, which means that it holds that much fluid when it is filled to the proper level.

**CARBON MONOXIDE** - A poisonous gas that is made while a fuel is burning, especially if there is not quite enough air. The gas is colorless, odorless, and tasteless, but it can cause illness or death. See the warnings on the Warning page at front of manual.

**COMBUSTION** - A chemical change, especially oxidation, accompanied by the production of heat and light. A combustion engine functions by burning a fuel to produce heat, i.e., energy.

**COMPONENT** - A part or a combination of parts which together accomplish a function.

**COMPRESSED AIR** - Air that is under pressure. When the compressed air in a hose or pipe is allowed to escape (such as when you use an air gun), the air moves very fast and is used to blow away dirt and chips for cleaning.

**CONDENSATION** - A liquid formed from a vapor. Moisture carried in warm air will condense when it reaches a cold area, such as the surface of a fuel tank in sub-zero weather.

**CONTAMINATED** - Made impure by contact or mixture. Exhaust fumes contain a poisonous gas which will contaminate the air in the nearby area.

**CORROSION** - A gradual wearing away caused by chemical action. Metals exposed to salt water are likely to corrode.

**COUPLING** - A device which connects a power source to a reducer and/or to a load; it will compensate for some misalignment and usually prevents metal to metal contact.

**D**

**DEBRIS** - The scattered remains of something broken or destroyed.

**DEFICIENCY** - An incompleteness; lacking an essential element.

**DETERIORATE** - A worsening of condition usually as a result of age or hostile environment, as opposed to mechanical damage.

**DIAPHRAGM** - An elastic material used as a boundary to seal and separate two areas. A pump diaphragm allows the volume of the pump bowl to be varied thus producing the pumping action.

**DIMINISH** - To make or become smaller or less important.

**DISTORTION** - The bending, twisting, or any other dynamic change of a surface.

**DRAW BAR** - A single piece handle used for lifting heavy objects.

**DRY ROT** - Rotting due to lack of air circulating around area.

**E**

EXHAUST - The gases that leave the vehicle engine through the tailpipe while the engine is running.

EXPENDABLE - An item that is not repairable and is discarded if damaged.

EXPOSURE - Being in the presence of something, or in contact with something. Skin is exposed to cleaning solvent when the solvent contacts the skin during cleaning operations.

**F**

FILTER - A device which removes dirt from the air or a fluid.

FLASH POINT - The lowest temperature at which the vapors of a solvent will ignite and burn.

FLAPPER - A restriction in a line which limits the flow of fluid, or gases, to a single direction. Flappers used in conjunction with a diaphragm pump and a power source enable the pump to push/pull fluid in desired direction.

FLUID - A substance which can flow; that is, either a gas or a liquid. The fluid used in the engine is gasoline.

**G**

GALLING - A condition in which transfer of metal occurs between two parts made of like material (usually steel), usually occurring when mated parts have limited relative motion under high loads.

GASKET - A seal or packing used between matched machine parts or around pipe joints to prevent the escape of gas or fluid.

GOGGLES - A device used to protect the eyes from dust, dirt, flying chips, etc.

**H**

HAZARD - A danger or risk.

**I**

IMMERSE - To completely cover by fluid.

INHALATION - The act of breathing in. The breathing in or inhalation of carbon monoxide can cause illness or death. Refer to the Warning page at front of manual.

INITIAL - The first or starting condition.

INNER RACE - A component of a bearing assembly upon which the needles or rollers ride; used to insure full contact and uniform surface condition.

**K**

KEYWAY - A channel machined in a shaft into which a length of hardened steel stock, usually rectangular in cross section, is inserted to prevent the relative motion of a mating part.

**L**

LEGIBLE - Capable of being read. A legible nameplate can be read; an illegible plate can not.

LUBRICANT - A material such as grease, or machine oil, that reduces friction, and preserves, when used as a coating on moving parts.

**M**

MALFUNCTION - Occurs when a unit fails to operate normally.

MANUFACTURER - The company which makes an item or piece of equipment for sale.

MATERIEL - Equipment, apparatus, and supplies of an organization such as an army.

**O**

OBSTACLE - Something that stands in the way of, or blocks progress toward, a goal.

OBSTRUCTION - An obstacle.

OPERATIONAL - Available for use in accordance with the applicable specification.

OUTPUT - The energy, power, or work produced by a system.

**P**

PIVOT - A short rod or shaft about which a related part rotates; the act of turning on or as if on a pivot.

PORT - A threaded hole through which fluid may pass, or pressure may be measured. Ports on the pump are used to connect hoses, and to measure pressure.

POTENTIALLY - Something which could possibly happen. Cleaning solvents are potentially dangerous, because fire or illness can result if safety instructions are not followed.

PRECAUTION - An action taken in advance to protect against possible failure or danger.

PRELIMINARY - Prior to the main action or business.

PRIME - The act of introducing a liquid into a pump to increase the pump's ability to overcome negative head pressure.

PROLONGED - A condition or situation which exists for an extended period of time.

PROTRUDING - Pushing or jutting outward; projecting.

PROVISIONS - Stipulations or qualifications. Also that which is provided; stock of necessary supplies.

**R**

RADIOLOGICAL - Using ionizing radiation, or radioactive waves or particles. Radiological protection shields the person or object from damage or injury due to harmful radiation.

RANGE - The minimum and maximum performance levels of any unit and including all measurable points between them.

RECIPROCATING - Equipment that acts along a straight line in alternating direction, i.e., the up and down motion of the connecting rod.

RECOMMENDATIONS - Suggestions for change; advise given usually to make an improvement.

REQUIRE - To demand or need.

RESERVOIR - A container for holding a fluid, such as oil or water, in readiness for use.

RESPIRATION - The process of breathing; inhaling and exhaling.

RESTRICTED - Limited, confined; prevented from moving. Also the reduction of cross-sectional area through which a gas or liquid must flow.

## S

SCOPE - The extent of an activity or concept; the amount of information covered as in a book.

SHAFT - A round rod or bar which rotates to transfer rotary motion or torque.

SHOCK - An extreme stimulation of the nerves and muscles caused by the passage of electric current through the body. Also damage caused to mechanical equipment as a result of sudden stoppage of motion.

SLINGING - Using a looped or hanging strap to raise and lower a heavy object, or for carrying or supporting something.

SOLVENT - A liquid that can dissolve another substance.

STREET ELBOW - A pipe fitting which changes direction of flow 90 degrees.

STUD - A type of fastener, or alignment device, which has one end attached to a surface and the other end protruding from that surface. The protruding portion of the stud may be used as an alignment aid or, if threaded, as a fastener.

SYMPTOM - The external sign or indication of a condition.

## T

TIEDOWN - Strap or fastening device used to hold an object in position.

TORQUE - Force around an axis. It produces a rotary or twisting motion, and is measured in foot pounds (ft lb) or newton-meters (N•m).

## V

VALVE - A device used to control the flow of a fluid.

VAPOR - The gaseous form of any substance which is usually a liquid; vapors are present in the air around the substance.

VENTILATE - To provide with a source of fresh or uncontaminated air.

VISUAL - Visible; detected by the unaided eye.

## W

WARPAGE - The twisting, bending, or other distortion of an object which alters its shape.

ALPHABETICAL INDEX

**Subject, Para**

**A**

Accumulator  
 Repair, 5-9  
 Maintenance, 4-19  
 Adjustments  
 Initial, 2-4  
 Preliminary, 4-5a  
 Administrative Storage, 4-28  
 Assembly and Preparation for Use, 2-3

**C**

Frame Assembly  
 Capabilities, 1-8  
 Characteristics, 1-7  
 Checks and Services, Preventive Maintenance  
 (Organizational), 4-7  
 Checks, Operational  
 Operator/Crew, 3-3  
 Organizational, 4-6  
 Clamp Assembly Maintenance, 4-22  
 Cleaning, 3-5  
 Common Tools and Equipment  
 Direct Support, 5-1  
 Organizational, 4-1  
 Connecting Rod Assembly Maintenance, 4-24  
 Connecting Rod Repair, 5-10  
 Coupling Maintenance, 4-25  
 Crank Repair, 5-10  
 Humid Conditions, Operation Under, 2-14

**D**

Data, Equipment, 1-11  
 Data Plates Maintenance, 4-18  
 Description of External Components, 1-9  
 Destruction of Army Materiel to  
 Prevent Enemy Use, 1-3  
 Diaphragm Maintenance, 4-21  
 Diaphragm Pump, 1-12  
 Discharge Port  
 Maintenance, 4-20  
 Repair, 5-9  
 Dusty Areas, Operation in, 2-13

**E**

Enemy Use, Destruction to Prevent, 1-3  
 Engine Maintenance, 4-12  
 Equipment  
 Common, Direct Support, 5-1  
 Common, Organizational Maintenance, 4-1  
 Data, 1-11

**Subject, Para**

Improvement Recommendations, 1-5  
 Preliminary Servicing and Adjustment of, 4-5  
 Special, Direct Support, 5-2  
 Special, Organizational Maintenance, 4-2  
 External Components, Location and  
 Description of, 1-9  
 Extreme Cold, Operation in, 2-10  
 Extreme Heat, Operation in, 2-11

**F**

Features, 1-8  
 Maintenance, 4-16  
 Repair, 5-7  
 Fuel Filter Maintenance, 4-13  
 Fuel Line Maintenance, 4-15  
 Fuel System, Servicing, 3-4  
 Fuel Tank Maintenance, 4-14

**G**

Gear Reducer  
 Maintenance, 4-26  
 Repair, 5-11

**H**

High Altitudes, Operation in, 2-12

**I**

Identification Plate, 1-10  
 Initial Adjustments, 2-4  
 Inspection, Pump Assembly, 4-11

**L**

Location of External Components, 1-9  
 Lubrication, 3-1, 4-5b

**M**

Maintenance Forms, Records, and  
 Reports, 1-2  
 Maintenance Procedures  
 Accumulator, 4-19  
 Clamp Assembly, 4-22  
 Connecting Rod Assembly, 4-24  
 Coupling, 4-25  
 Data Plates, 4-18

**Subject, Para**

Diaphragm, 4-21  
 Direct Support, 5-6  
 Discharge Port, 4-20  
 Engine, 4-12  
 Frame Assembly, 4-16  
 Fuel Line, 4-15  
 Fuel Filter, 4-13  
 Fuel Tank, 4-14  
 Gear Reducer, 4-26  
 Operator/Crew, 3-2  
 Organizational, 4-10  
 Pump Assembly Inspection, 4-11  
 Pump Bowl, 4-23  
 Wheel Assembly, 4-17  
 Movement to a New Worksite, 2-9

**O**

Operating Procedure, 2-5  
 Operating Procedure Plate, 1-10  
 Operation  
     In Extreme Cold, 2-10  
     In Extreme Heat, 2-11  
     In High Altitudes, 2-12  
     In Salt Water Areas, 2-15  
     In Sandy or Dusty Areas, 2-13  
     Under Rainy or Humid Conditions, 2-14  
     Under Usual Conditions, 2-7  
 Operational Checks  
     Operator/Crew, 3-3  
     Organizational, 4-6  
 Storage

**P**

Packing and Shipping, 4-29  
 Preliminary Servicing of Equipment, 4-5a  
 Preparation for Storage and Shipment, 4-27  
 Preparation for Use, 2-3  
 Preventive Maintenance Checks and Services  
     Operator/Crew, 2-2  
     Organizational, 4-7  
 Principles of Operation, 1-12  
 Procedure, Operating, 2-5  
 Pump  
     Bowl Maintenance, 4-23  
     Capabilities and Features, 1-8  
  
     Characteristics, 1-7  
     Inspection, 1-11  
     Principles of, 1-12  
     Purpose of, 1-6  
     Repair, 5-8

**R**

Rainy Conditions, Operation Under, 2-14  
 Reducer, Gear  
     Maintenance, 4-26  
     Repair, 5-11

**Subject, Para**

Repair  
     Accumulator, 5-9  
     Connecting Rod, 5-10  
     Crank, 5-10  
     Discharge Port, 5-9  
     Frame Assembly, 5-7  
     Gear Reducer, 5-11  
     Pump, 5-8  
 Repair Parts  
     Direct Support, 5-3  
     Organizational, 4-3  
 Reporting Equipment Improvement  
     Recommendations (EIR), 1-5

**S**

Salt Water Areas, Operation in, 2-15  
 Sandy Areas, Operation in, 2-13  
 Scope, 1-1  
 Service Upon Receipt of Materiel, 4-4  
 Servicing Fuel System, 3-4  
 Shipment, Preparation for, 4-29  
 Spares  
     Direct Support, 5-3  
     Organizational, 4-3  
 Special Tools  
     Direct Support, 5-2  
     Organizational, 4-2  
 Starting, 2-6  
 Stopping, 2-8  
  
     Preparation for, 4-27  
     Administrative, 4-28  
 Support Equipment  
     Direct Support, 5-2  
     Organizational, 4-2  
 Symptom Index  
     Direct Support, 5-5  
     Organizational Maintenance, 4-9

**T**

Tools  
     Common, Direct Support, 5-1  
     Common, Organizational Maintenance, 4-1  
     Special, Direct Support, 5-2  
     Special, Organizational Maintenance, 4-2  
 Troubleshooting  
     Direct Support, 5-4  
     Operator/Crew, 3-1  
     Organizational Maintenance, 4-8

**W**

Wheel Assembly Maintenance, 4-17  
 Worksite, Movement to, 2-9

By Order of the Secretary of the Army:

**E. C. MEYER**  
*General, United States Army*  
*Chief of Staff*

Official:

**ROBERT M. JOYCE**  
*Major General, United States Army*  
*The Adjutant General*

**DISTRIBUTION:**

To be distributed in accordance with DA Form 12-25A, Operator's and Organizational Maintenance requirements for Pumps, Fresh Water



RECOMMENDED CHANGES TO EQUIPMENT TECHNICAL PUBLICATIONS



THEN...JOT DOWN THE  
DOPE ABOUT IT ON THIS FORM.  
CAREFULLY TEAR IT OUT, FOLD IT  
AND DROP IT IN THE MAIL.

SOMETHING WRONG WITH PUBLICATION

FROM: (PRINT YOUR UNIT'S COMPLETE ADDRESS)

DATE SENT

PUBLICATION NUMBER

PUBLICATION DATE

PUBLICATION TITLE

BE EXACT PIN-POINT WHERE IT IS

PAGE  
NO.

PARA-  
GRAPH

FIGURE  
NO.

TABLE  
NO.

IN THIS SPACE, TELL WHAT IS WRONG  
AND WHAT SHOULD BE DONE ABOUT IT.

TEAR ALONG PERFORATED LINE

PRINTED NAME, GRADE OR TITLE AND TELEPHONE NUMBER

SIGN HERE

## THE METRIC SYSTEM AND EQUIVALENTS

### Linear Measure

1 centimeter = 10 millimeters = .39 inch  
 1 decimeter = 10 centimeters = 3.94 inches  
 1 meter = 10 decimeters = 39.37 inches  
 1 dekameter = 10 meters = 32.8 feet  
 1 hectometer = 10 dekameters = 328.08 feet  
 1 kilometer = 10 hectometers = 3,280.8 feet

### Weights

1 centigram = 10 milligrams = .15 grain  
 1 decigram = 10 centigrams = 1.54 grains  
 1 gram = 10 decigrams = .035 ounce  
 1 dekagram = 10 grams = .35 ounce  
 1 hectogram = 10 dekagrams = 3.52 ounces  
 1 kilogram = 10 hectograms = 2.2 pounds  
 1 quintal = 100 kilograms = 220.46 pounds  
 1 metric ton = 10 quintals = 1.1 short tons

### Cubic Measure

1 cu. centimeter = 1000 cu. millimeters = .06 cu. inch  
 1 cu. decimeter = 1000 cu. centimeters = 61.02 cu. in.  
 1 cu. meter = 1000 cu. decimeters = 35.31 cu. feet

### Square measure

1 sq. centimeter = 100 sq. millimeters = .155 sq. in.  
 1 sq. decimeter = 100 sq. centimeters = 15.5 inches  
 1 sq. meter (centare) = 100 sq. decimeters = 10.76 feet  
 1 sq. dekameter (are) = 100 sq. meters = 1,076.4 sq. ft.  
 1 sq. hectometer (hectare) = 100 sq. dekameters = 2.47 acres  
 1 sq. kilometer = 100 hectometers = .386 sq. miles

### Liquid Measure

1 dekaliter = 10 liters = 2.64 gallons  
 1 hectoliter = 10 dekaliters = 26.42 gallons  
 1 kiloliter = 10 hectoliters = 264.18 gallons  
 1 liter = 10 deciliters = 33.81 fl. ounces  
 1 centiliter = 10 milliliters = .34 fl. ounce  
 1 deciliter = 10 centiliters = 3.38 fl. ounces  
 1 metric ton = 10 quintals = 1.1 short tons

### Approximate Conversion Factors

To change	To	Multiply by	To change	To	Multiply by
inches	centimeters	2.540	ounce inches	newton-meters	.0070062
feet	meters	.305	centimeters	inches	.394
yards	meters	.914	meters	feet	3.280
miles	kilometers	1.609	meters	yards	1.094
sq. inches	sq. centimeters	6.451	kilometers	miles	.621
sq. feet	sq. meters	.093	sq. centimeters	sq. inches	.155
sq. yards	sq. meters	.836	sq. meters	sq. yards	10.764
sq. miles	sq. kilometers	2.590	sq. kilometers	sq. miles	1.196
acres	sq. hectometers	.405	sq. hectometers	acres	2.471
cubic feet	cubic meters	.028	cubic meters	cubic feet	35.315
cubic yards	cubic meters	.765	milliliters	fluid ounces	.034
fluid ounces	milliliters	29.573	liters	pints	2.113
pints	liters	.472	liters	quarts	1.057
quarts	liters	.946	grams	ounces	.035
gallons	liters	3.785	kilograms	pounds	2.205
ounces	grams	28.349	metric tons	short tons	1.102
pounds	kilograms	.454	pound-feet	newton-meters	1.356
short tons	metric tons	.907			
pound inches	newton-meters	.11296			

### Temperature (Exact)

°F Fahrenheit temperature

5/9 ( after subtracting 32)

Celsius Temperature °C

